

# Drive Systems for Construction Machines.

Linde Hydraulics

*Linde*



# Competence in Construction Machinery. Innovative Solutions improve Efficiency.

Key factors to be considered when designing modern construction machines include market-specific requirements, regulations for noise and exhaust emissions, such as Tier 4, and reducing the total cost of ownership while at the same time improving performance. We would like to master these challenges together with you. We are able to draw on 50 years of experience in this field: experience in system design and the commissioning of construction machinery, as well as in developing innovative components and drive systems that fulfill the diverse requirements of the global markets and improve energy efficiency.

The Linde Synchron Control System (LSC) is one example of how we have improved energy efficiency. The demand-based volume flow regulation of the self-regulating pump combined with the avoidance of circulation losses due to the "closed center" design of the directional control valves prevent energy loss and thus fuel waste.

Compared to other systems, LSC saves up to 10% fuel. The latest generation of the System, called LSC+, is controlled electro-hydraulically and offers a number of advantages, including adjustable machine behavior. The operator thus improves the efficiency in every situation.

This system-level analysis and intelligent combination of hydraulics, electric drive technology, electronics and mechanics give us the tools we need to design first-class complete solutions for your applications.



# Collaboration is the Key to Success.

All of the benefits offered by the individual system components can only be fully realized if the overall system is perfectly coordinated. We want our customers' machines to set the benchmark in terms of high productivity, low fuel consumption, optimum adaptability to any given task and long service life. We are able to achieve this goal by working in partnership with our customers, already during the development stage. We provide our customers with solution-oriented advice and support them

from the product proposal stage right the way through to the technical approval of machines ready for series production. This way of working enables us to develop drive systems that set themselves apart from standard solutions in terms of performance and operation. Our sales and application engineers are committed to providing you with professional support when it comes to optimizing your hydraulic systems. Any time, any place.



# Service. Reliability is Key.

With subsidiaries in Europe, the USA and China, our strategic distribution partner for the USA and Asia Pacific, Eaton Hydraulics, and our representatives around the world, we guarantee that you will enjoy a reliable and competent service. Our sales organization is connected to the central spare parts warehouse in Germany via the Internet, ensuring that you receive original Linde spare parts wherever you are in the world — quickly, easily and securely. Remanufacturing-Programm mit Neuwert-Garantie.

As well as supplying spare parts and carrying out repairs, our service team also provides a remanufacturing program with “as new” warranty. We provide training to our customers' employees in the area of product and assembly technology either at our training center or at the customer site. We also offer application-specific system training sessions.



# The Social Flow. Linde Synchron Control.

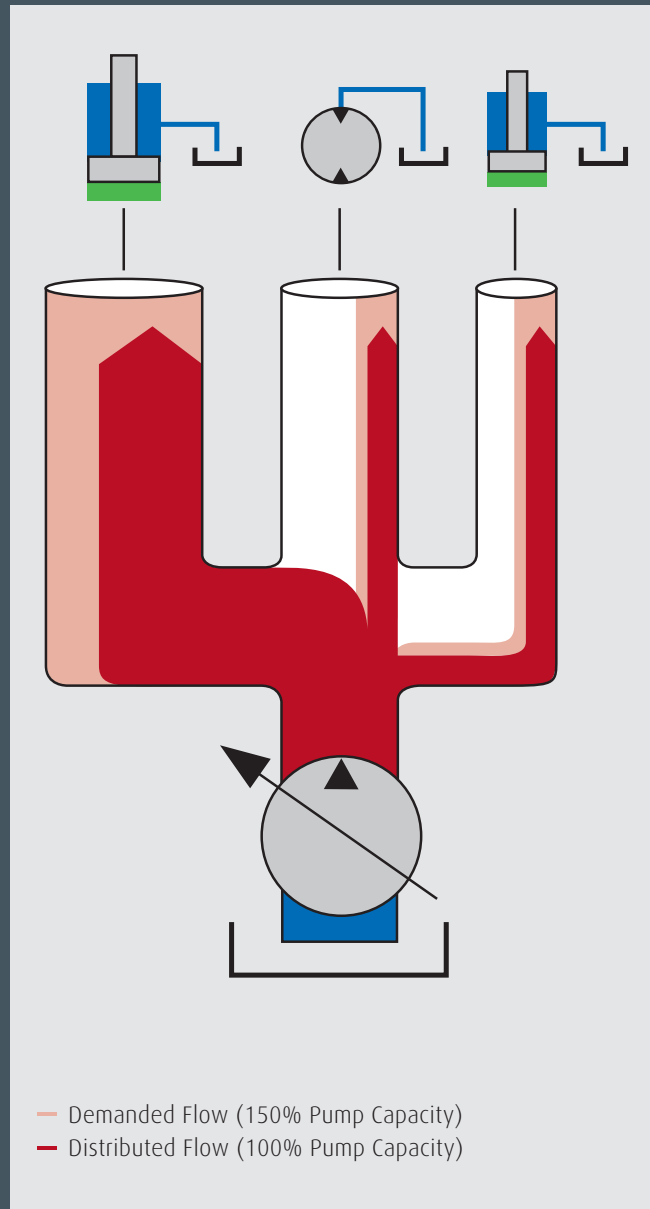

Linde Synchron Control (LSC) is a valve technology system for open high-pressure hydraulic circuits. It is a load-sensing (LS) system that consistently guarantees identical machine responses in terms of sensitivity and speed when the operator's input is the same. It does this independent of the load involved, and even when there are multiple actuators of different pressure levels. It stands out from other LS systems thanks to its pressure compensators, which are logically set downstream and enable proportional flow distribution. If the volume required by all actuators exceeds the delivery rate of the installed pump(s), no actuator will suddenly stop. Instead, all actuators will be reduced accordingly and the installed power will be utilized in an optimal way. Machines with LSC are therefore intuitive to operate while enabling reproducible workflows and guaranteeing excellent handling performance. It is also highly efficient: The demand-based pressure and volume flow regulation ensures that the prime mover only has to provide precisely as much power as the task requires. This saves energy, particularly in partial-load operational range. Closed center valves only open once the pump pressure has reached the load pressure level, preventing any lowering of the load in idle mode and at the beginning of the movement. In addition, no circulation flows are required when the machine is idle. The pump can be set to a minimum level and there is practically no loss of power. The system therefore saves a substantial amount of fuel, particularly in comparison to systems with circulation pressure compensator and open center designs. The LSC features parallel system architecture. This means that additional actuators (at additional directional control valve sections) can be easily integrated into the system without altering the existing components or resetting the machine. Multiple circuit systems are also possible. The system and its components are therefore basically the same for every sort of machine. Application-specific requirements can be implemented via individual A- and B-side characteristics, adjustable flow regulators, pressure increase and priority functions as well as pressure and speed regulation.

The result is a machine that offers consistently intuitive and sensitive operation with the ideal setup.

## Design

- Load Sensing System with downstream pressure compensators (post-compensated LS)
- Parallel architecture (common LS signal for all actuators)
- Directional control valves in closed center design

## Functionality

- Highly dynamic pump controller
- Demand-based supply to actuators
- Simultaneous movements of several actuators, independent of the load
- Proportional oil distribution even at saturation
- Load held in position when movement begins
- Outstanding fine control, no need for readjustment
- Machine movements can be reproduced exactly through precise control of actuators
- Optional additional functions

## Advantages

- Precise and sensitive control
- Simple, intuitive operation
- Optimal movement continuity even for combined movements
- Effortless and efficient work
- Perfect calibration of individual work functions for a customer-specific machine characteristic
- Superior handling performance
- Low fuel consumption
- Excellent energy efficiency

# LSC<sup>+</sup>. Adaptive Electro-hydraulic Control.

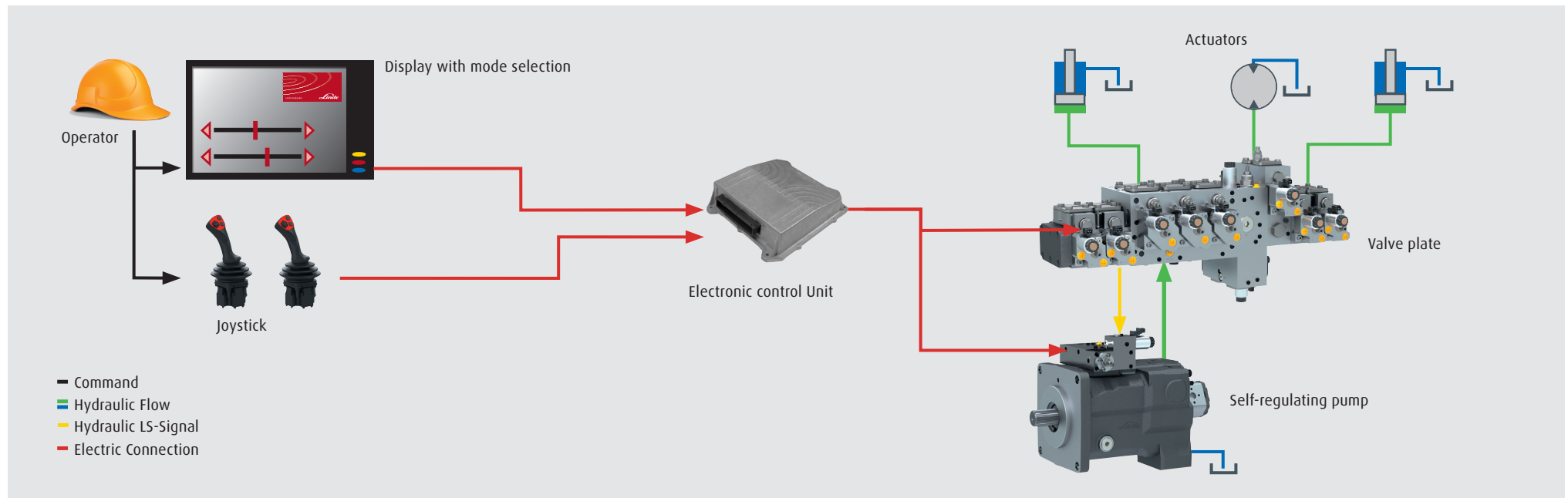

With its latest LSC generation, LSC+, Linde combines the design characteristics of the proven LSC system with the benefits of the electric control.

The powerful electronic control unit recognises the operator's command by the amplitude and the speed with which the joysticks are being moved. It then sets the pump and the valves according to the dynamic demand. Due to the overlaid, classic load-sensing control mechanism, no sensors are needed. All components are provided by a single source and matched perfectly with each other. The operator can change the system's behaviour electronically with regard to its dynamics and fine control, as well as its dependency or independency on the load.

This enables multi-purpose machines which can quickly be optimized to the specific use by the operator. With completely opened valves, the actuators can be controlled exclusively via the pump's control to achieve the maximum possible efficiency.

## Product advantages

- Direct response behaviour
  - Most simple machine operation
  - Further increase in energy efficiency
  - Automatic recognition of the working condition in high dynamic or fine control mode
  - Automatic optimization of typical tasks like grading or shaking the bucket of an excavator
  - Manual adjustment of load dependent or load independent system behaviour and system dynamics by the operator
- Optional prioritization of actuators with each other enables

# Product Overview.

## High-Pressure Variable Displacement Pumps for Closed Circuits

Swash plate axial piston pumps with 55–280 cc displacement and mechanical, hydraulic or electric control.

### Design Characteristics

- Clockwise or counter-clockwise rotation
- Precise and robust servo controls
- Integrated high-pressure relief valves with make-up function
- Integrated low-pressure valves for charge, control and cooling circuit
- Charge pressure pumps for internal and external suction, optional integrated cold start valve
- Option of tandem or multiple pumps

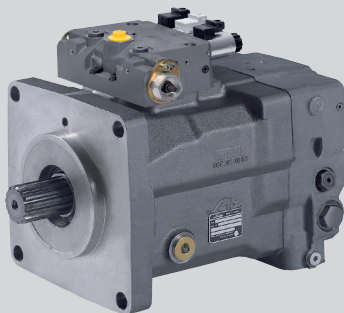

## High-Pressure Self-Regulating Pumps for Open Circuits

Swash plate axial piston pumps with 55–280 cc displacement and load sensing controller with hydraulic or electric override options.

### Design Characteristics

- Clockwise or counter clockwise rotation
- Self-priming with high nominal speed
- Precise and robust load-sensing controller
- Pump controller with or without swashplate position feedback
- Adaptive noise optimization SPU Decompression fluid discharged via pump housing to keep suction side calm

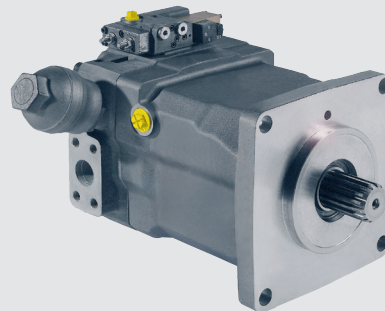

## High-Pressure Hydraulic Motors for Closed and Open Circuits

Swash plate axial piston motors with fixed or variable displacement of 28–330 cc. Electric or hydraulic control.

### Design Characteristics

- Fixed displacement motor
- Self-regulating motor with various  $V_{max}$  override options
- Variable displacement motor with position feedback and various control types and characteristics
- Plug-in motor
- PTO through-drive motor
- Double motors with common control
- Tandem motors

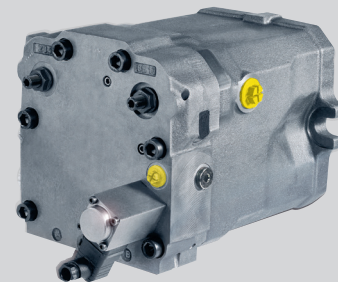

Bent axis axial piston motors with fixed or variable displacement of 60–215 cc. Electric or hydraulic control.

### Design Characteristics

- Fixed displacement motor
- Variable displacement motor
- Standardized interfaces (e.g. plug-in flange)
- Wide range of options (e.g. speed sensor)

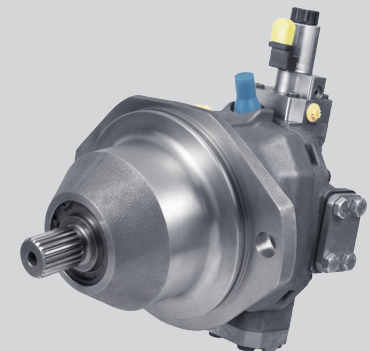

## Compact Units for CVT drives

Variable displacement pump and fixed displacement motor in one common unit with integrated high pressure relief valves with charge and discharge function.

### Design characteristics

- Inline, U- or Z- design
- Version for installation in powersplit transmissions
- Version for gearbox with PTO option or fully hydrostatic units
- Accurate control of the displacement
- Standstill control and precise crawling speed

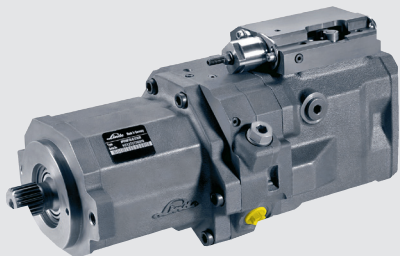

## Monoblock Control Valves

Three directional control valves in a common cast housing form the base of the manifold valve plate in monoblock design. They can be piloted hydraulically or electro-hydraulically.

### Design Characteristics

- Designed for the Linde Synchron Control (LSC) load-sensing system
- Flows up to 250 l/min (size 18), 400 l/min (size 25) or 600 l/min (size 30)
- Large cross-sections and flow-optimized supply channels
- Can be expanded using valves in sandwich design in an identical or differing nominal size
- Pressure cut-off and additional functions integrated in connection plate
- Special functions available via intermediate plates

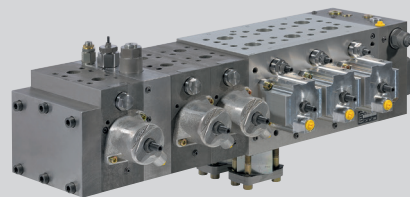

## VTmodular Control Valves

VT modular manifold valve plates are made up of individual components from one modular building block system. They can be piloted hydraulically, electro-hydraulically or in combinations of both.

### Design Characteristics

- Directional control valves as sub plate mounted valves
- Designed for the Linde Synchron Control (LSC) load sensing system
- Rated sizes 25 and 30
- Flow quantity up to 600 l/min (size 30)
- Modular building block design for configuring manifold valve plates for 1–8 actuators

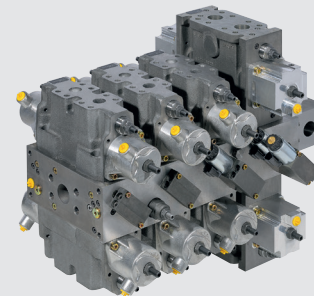

## Electronic Controls and Peripheral Equipment

Modern machines benefit from the advantages of an intelligent electronic control and coordinated peripheral devices, such as joysticks, power modules and sensors.

### Design Characteristics

- Operating voltage 8–32 VDC
- Preconfigured setup
- Freely definable switch and proportional outputs
- Redundant safety concept with function and safety controller
- Communication via CAN bus

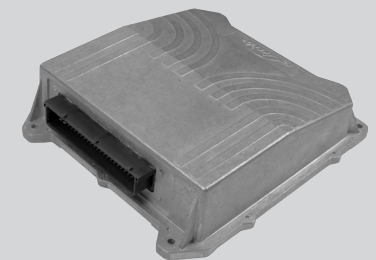

# Wheel Loader.

## Linde Standard Product Portfolio

3 t - 15 t

### Application Example

6.5 t

### Equipment

1x HPV 75-02 E2 (travel circuit pump)

1x HMV 105-02 E6 (travel circuit motor)

1x iCon base (electronic control unit)

### Advantages

- Maximum energy efficiency thanks to optimized components with intelligent system coordination
- High machine availability owing to minimum, plannable service thanks to heavy-duty units with long service life

### Options

- Shift in Motion (see example)
- K-02 compact unit possible
- Larger wheel loaders without hydrostatic drive unit benefit from Linde HPR self-regulating pumps and LSC valve technology in the working group and a hydrostatic fan drive

Optimised components are often not enough to help realise ambitious targets when it comes to fuel savings and comfort.

Real advantages can only be achieved if the system components are perfectly coordinated with each other and work as one overall system. The following sample of a wheel loader demonstrates this.

Linde Hydraulics has developed a system to receive considerable reduction of fuel consumption and noise emissions as well as lower initial and operating costs. This innovative system called Shift in Motion for hydrostatic drive consists of a variable displacement pump, a variable displacement motor, a shift actuator and an electronic control unit.

It enables shifting procedures in a moving machine, equipped with a manual transmission that is intended to be shifted at standstill by electro-hydraulically synchronising the drivetrain. This system is particularly suitable for vehicles that require both, high tractive effort and a high top speed above 25 km/h - for example for small and compact wheel loaders.

The shifting procedure is load-free thanks to electro-hydraulically synchronised gears and the ability to adjust the drive component's speed and torque. Thus there is no need for multi-disc clutches and mechanical synchronisation using synchronizer rings and moreover there's less pinion engagement. This makes the shifting procedures wear-free and also increases the transmission's efficiency.

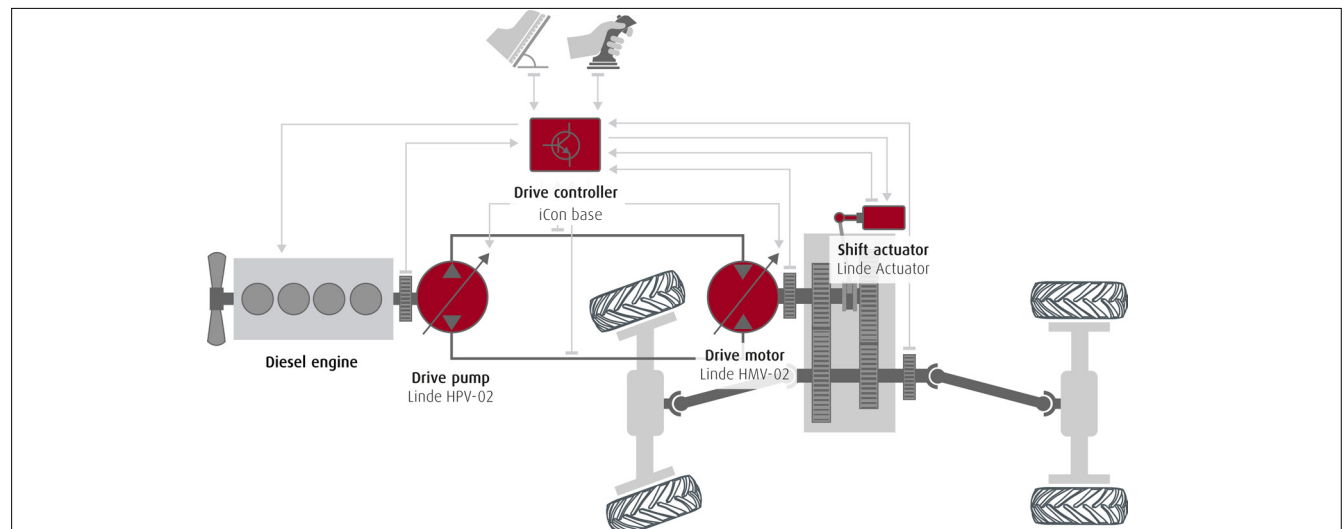



### Equipment

- A** 1x HPV 75-02 E2
- B** 1x HMV 105-02 E6
- C** 1x iCon base



### Category



# Wheeled Excavator.

## Linde Standard Product Portfolio

12 t - 28 t

## Application Example

20 t

## Equipment

1x HPR 210-02 E1L SPU (working hydraulics)

1x HMF 75-02 (swing drive motor)

1x HMR 135-02 (travel circuit motor)

1x VW25M3 (directional control valves)

1x iCon base (electronic control unit)

## Advantages

- Intuitively operated universal machine
- Social flow distribution
- Fatigue-free working
- Minimal pulsation

## Options

- Single-circuit or multi-circuit systems
- Adjustable behaviour via speed controls
- Adjustable start of movement, regardless of A or B side
- Hydraulic or electrohydraulic actuation
- LSC<sup>+</sup>

The LSC system is intuitive and efficient. All machines with LSC feature sensitive and intuitive operation. The excavator shown, which is versatile and suitable for use in different situations, greatly benefits from this technology. Thanks to the compensation of the load influences, the machine response is always the same, regardless of which functions are operated at the same time and even if the valves are not arranged on the same control plate, as shown in this example with a swing drive motor with integrated directional control valve.

A single LS signal is enough for all actuators. As such, the driver never has to make any post-adjustments and can always concentrate fully on the task at hand. The machine is highly sensitive with continuous movements and does not experience any jerking, even at the start of movements. The directional control valves do not open the paths until the pump pressure matches the load pressure. This means the load at the start of the function does not lower. Thanks to the social flow distribution, no actuators are stopped when the system is at full capacity.

As such, even challenging tasks can be completed without any post-adjusting or interruption of the movement sequence. High workloads are possible thanks to the system dynamics with fast-response pumps. This does not compromise on efficiency because the LSC system saves fuel compared with other concepts, even in the partial load range.

The operation is not the only reason that working with the machine is a pleasure; one of the best features of the pump is the SPU silencer. This reduces pressure pulsations in the hydraulic system, thereby reducing the vibrations and noise emissions of the overall machine. This means that the excavator is comparatively quiet, which benefits not only the operator, but also the environment; something that is particularly useful in residential areas. Unlike other solutions, the SPU works across the entire typical speed range of the prime mover, reducing the pulsations of an open circuit almost to the level of a closed circuit.

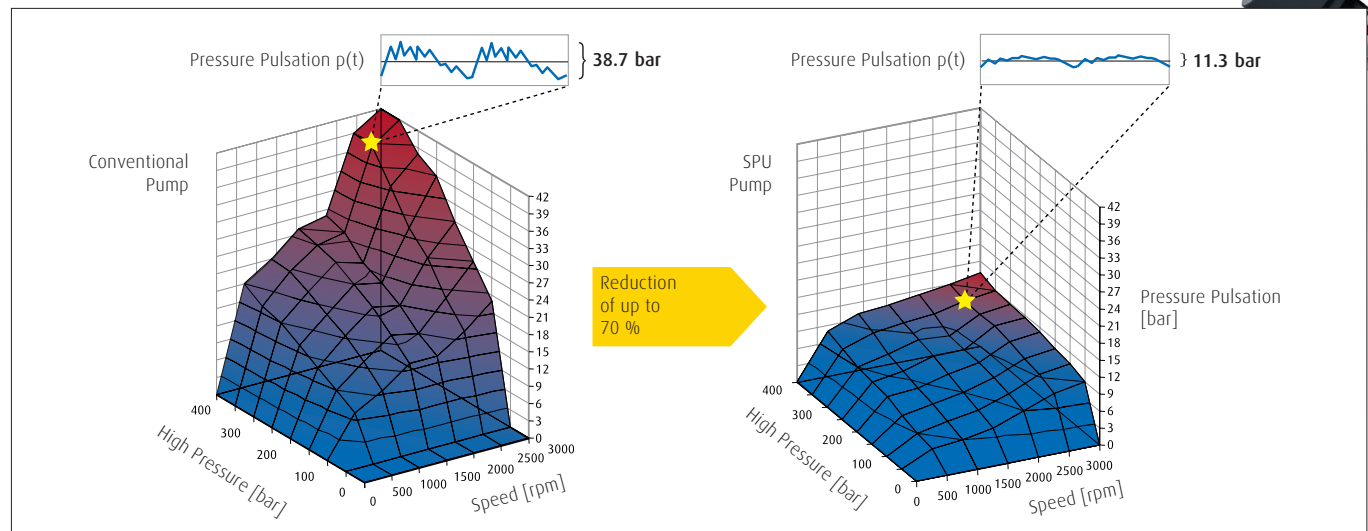

**Equipment**

- A** 1x HPR 210-02 E1L SPU
- B** 1x HMF 75-02
- C** 1x HMR 135-02
- D** 1x VW25M3
- E** 1x iCon base



**Category**

12 t

20 t

28 t

# Drilling Machine.

## Linde Standard Product Portfolio

160 - 450 kNm

## Application Example

260 kNm

## Equipment

2x HMV 280-02 (drill drive motor)

1x HPR 165D-02 (main pump)

1x CMF 80 (swing drive motor)

1x HMF 105-02 (winch motor)

2x VT8 (main control valve)

1x iCon base (electronic control unit)

## Advantage

- Freely configurable

## Option

- Hydraulic or electric control

The LSC system is high-performance and adjustable. Machines with LSC are not only intuitive, easy to use, and versatile, but are also extremely powerful, as this example of a drilling machine shows.

The double pump in the design example provides the hydraulic power for the machine with 700 litres of oil per minute and can be used as a single-circuit or double-circuit pump.

Basic machines for demolition work stand out thanks to another feature of LSC technology: the parallel architecture. The compact design of the Manifold also allow additional functions to be added later. Sandwich valves with a range of nominal sizes can be added or exchanged to the existing sections and use pump and tank channels as well as the LS signal. However, the real advantage is that the system does not need to be recalibrated neither the orifices need to be exchanged.

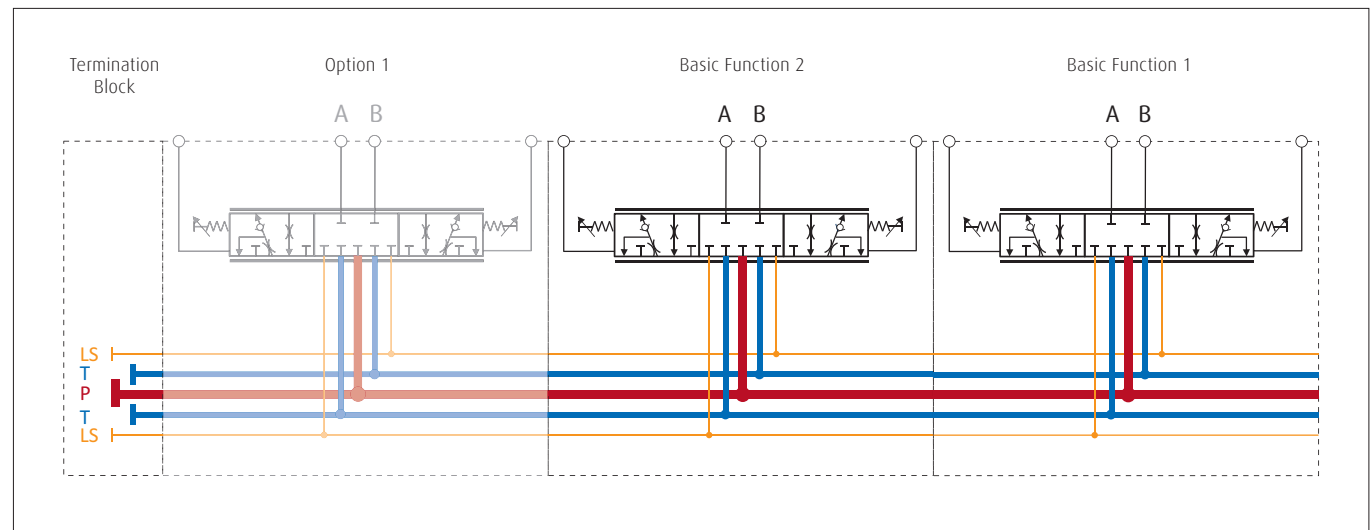

Equipment

- A** 2x HMV 280
- B** 1x HPR 165D -02
- C** 1x CMF 80
- D** 1x HMF 105
- E** 2x VT8
- F** 1x iCon base

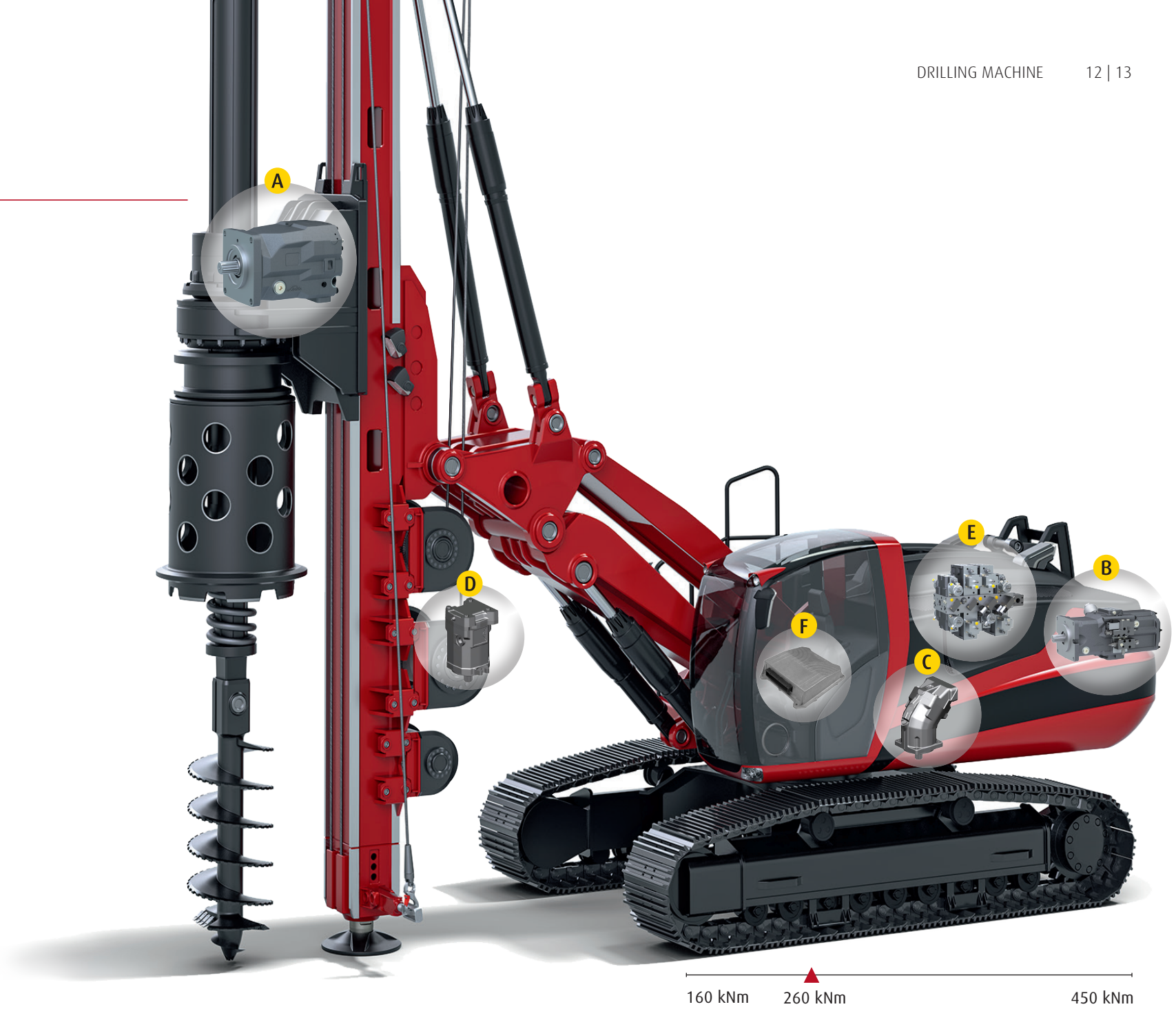

# Walking Excavator.

## Linde Standard Product Portfolio

7 t - 12 t

### Application Example

9.8 t

### Equipment

1x HPR 105-02 E1L + HPV 75-02 E2 ( )

2x VW14M3 (directional control valve monoblocks)

2x CMV 60 E600 (travel circuit pump)

1x iCon base (electronic control unit)

### Advantages

- Most compact dimensions of hydraulic components
- High performance electronic controller for simultaneous actuation of open and closed circuits

LSC is versatile and compact. Special machines require special systems. If maximum power is needed in different environments and tight spaces, Linde components pack a lot of punch despite their small size.

Thanks to the 21° swash angle technology, series 02 self-regulating and variable displacement pumps are among the most compact on the market. Because they can be used in tandem configurations and have a special housing with an SAE clutch bell, the two can be connected quickly and they save space in the machine room where every centimetre counts.

The motors of the drive unit are also exceptionally space saving: the plug-in housing means they are positioned directly at the wheels, ensuring smooth driving.

Boom, stick, bucket, telescopic arm, hoist gear, outriggers, and much more: to position the directional control valves perfectly in the machine, despite their large numbers, they are distributed across two separate control plates. Their monoblock design stands out thanks to its high level of integration. Several directional valve sections are combined with additional functions such as the pressure limitation in one compact cast housing. The electronic control unit of this machine deserves particular attention since it controls the key functions in the open circuit as well as the drive components of the closed circuit.





**Equipment**

- A** 1x HPR 105 E1L + HPV 75-02 E2
- B** 2x VW14M3
- C** 2x CMV 60 E600
- D** 1x iCon base

**Category**



# Dozer.

## Linde Standard Portfolio

8 t - 70 t

### Application Example

22 t

### Equipment

2x HPV 135-02 E1 (travel circuit pumps)  
2x HMV 280-02 E1 (travel circuit motors)  
1x HPR 75-02 LP (working hydraulics pump)  
1x VM14M3 (working hydraulics)  
1x iCon base (electronic control unit)

### Advantages

- Hydrostatic drive system without splitter, gearbox and manual gearbox
- Infinitely variable
- Precise, controlled even travel
- Wear-free steering
- Extremely robust and durable series 02 units
- Precise results
- Low consumption

The robustness and durability of all series 02 components makes them a reliable drive technology solution for heavy machinery in the toughest conditions, as demonstrated by this example of a bulldozer. In addition, Linde components also help you to realise ambitious targets when it comes to fuel consumption and ease of operation, even at full load.

The machine operator simply sets the desired speed with the joystick and the electronic controller ensures even, straight travel. A control circuit has been developed for this purpose, as the following diagram shows. Two identical drivetrains consisting of a variable displacement pump and a variable motor each supply one side of the bulldozer. The speed of the motors is constantly monitored by speed sensors. If different ground conditions, obstacles, and other factors require an adjustment to the rotational speed or torque, the relevant units are controlled in relation to the current situation and the speeds of the two drivetrains are coordinated.

Individual control of the drivetrains also allows precise turning curves to be achieved, right through to turning on the spot without increased risk of wear to the brakes or chain. The motors are extremely robust when it comes to rapid angular acceleration, which makes them immune to tracks which skip a tooth on the sprocket.

Thanks to the large spread of the hydrostatic power train, there is no need for a manual gearbox and the machine can be driven stepless from standstill through to high speeds. The optimal traction means that thrust performance is always constantly high, even during cornering. Fuel consumption is comparatively low, even at full load. The high efficiency level of the hydrostatic drive units and an electronic power limit control ensure the diesel motor is working at favourable operating points all the time.

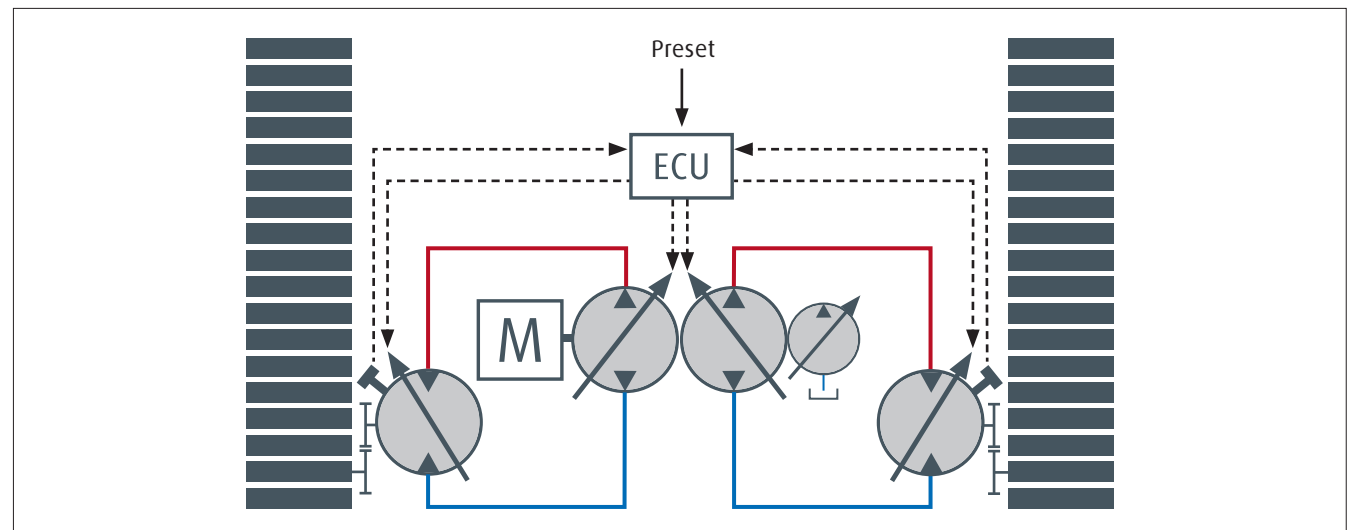



## Equipment

- A** 2x HPV 135-02 E1
- B** 2x HMV 280-02 E1
- C** 1x HPR 75-02 LP
- D** 1x VW14M3
- E** 1x iCon base



Category

8 t

22 t

70 t

# Crawler Crane.

## Linde Standard Product Portfolio

50 t - 3000t

### Application Example

75 t

### Equipment

1x HPR 210-02 + HPV 55-02 (pump tandem)

2x HMV 210-02 (track motors)

1x HMF 55-02 (swing drive motor)

2x CMV 115 E400 (winch motor)

1x VW 25 M3 (directional control valves)

1x iCon base (electronic control unit)

### Advantages

- Excellent low speed and true running behaviour of the motors
- Can be electrically controlled even for individual sections
- Smooth and precise control characteristics
- Weight/Power density
- Reduced power losses

### Options

- System scope and level of electrification can be scaled
- Partial automation

The crawler crane utilises the full benefits of LSC technology: the combined movement of individual functions without mutual interactions or influences in all load situations ensures perfect positioning. Furthermore, the crane also benefits from the smooth operation and no lowering of loads at the start of the movement. This ensures excellent load capacity in all working conditions. The superb low speed behaviour and the smooth, even running characteristic of the Linde motors is particularly noticeable when it comes to lifting and lowering the hook.

The valve sections in the control block can be actuated fully hydraulically or electro-hydraulically. The two types of control can also be combined in one control block.

Thanks to the electronic controller, selected functions can also be operated by remote control or partially automated. Sophisticated safety systems are also possible, which can be implemented via locking mechanisms or through proportionally slower reactions from individual actuators in given situations. Even without the use of position sensors, the machine can be equipped with the functions of the LSC+ system.

In particular, this includes switching between rough control or fine control, or overriding the LS signal if load-dependent machine reactions are required. The maximum efficiency of single actuators is achieved, when they are controlled purely via the pump with fully open directional control valve pistons.

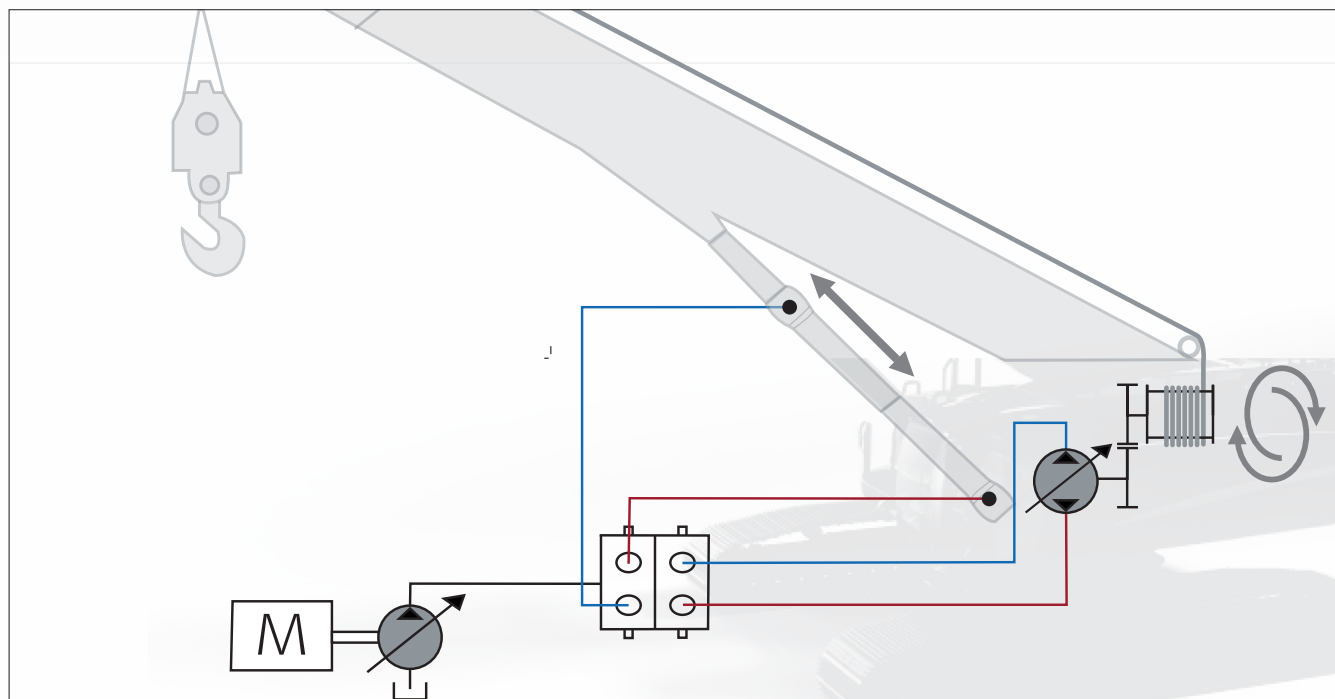

### Equipment

- A** 1x HPR 210-02 + HPV 55-02
- B** 2x HMV 210-02
- C** 1x HMF 55-02
- D** 2x CMV 115 E400
- E** 1x VW25 M3
- F** 1x iCon base



### Category



# Road Paver.

## Linde Standard Product Portfolio

5m - 13m

### Application Example

9m

### Equipment

2x HPV 55-02 E1P (tandem pump)

2x CMV 60 E400 (travel circuit motor)

1x iCon base (electronic control unit)

### Advantages

- Compact design with high power density
- High control dynamics
- High starting torque

### Options

- Maximum pressure limited by electronics, rather than valves
- Wheel-driven variants

Millimetre-precision work across long distances and under changing conditions. Road-surfacing machinery of all types present significant challenges to the drive unit. Linde Hydraulics meets these challenges, delivering drive units that fulfil the toughest requirements.

Two identical drivetrains consisting of a variable displacement pump and a variable motor each supply one side of the surfacing machine. The specific dimensions of the machine with its tight spaces require a special motor version. The solution is a variable motor with a plug-in design, which even includes a speed sensor in its compact housing. This continuously monitors the speed and reports it to the electronic control unit, which permanently adjusts all drive components, ensuring an even surface. Not only does it control the components of the drivetrain to achieve a perfect line and defined curves, but it also adjusts other drives such as the scraper belt and distributor auger to suit the situation.

The controller is CAN-bus compatible and can therefore communicate easily with additional functions such as an automated level regulation.

The motors stand out thanks to their excellent low speed behaviour. They move jolt-free and evenly, even at very slow speeds or where different speeds are required. Everything functions optimally combined with the series 02 high-pressure pumps, whose unique adjustments ensure precision supply even with minimal volume flows.

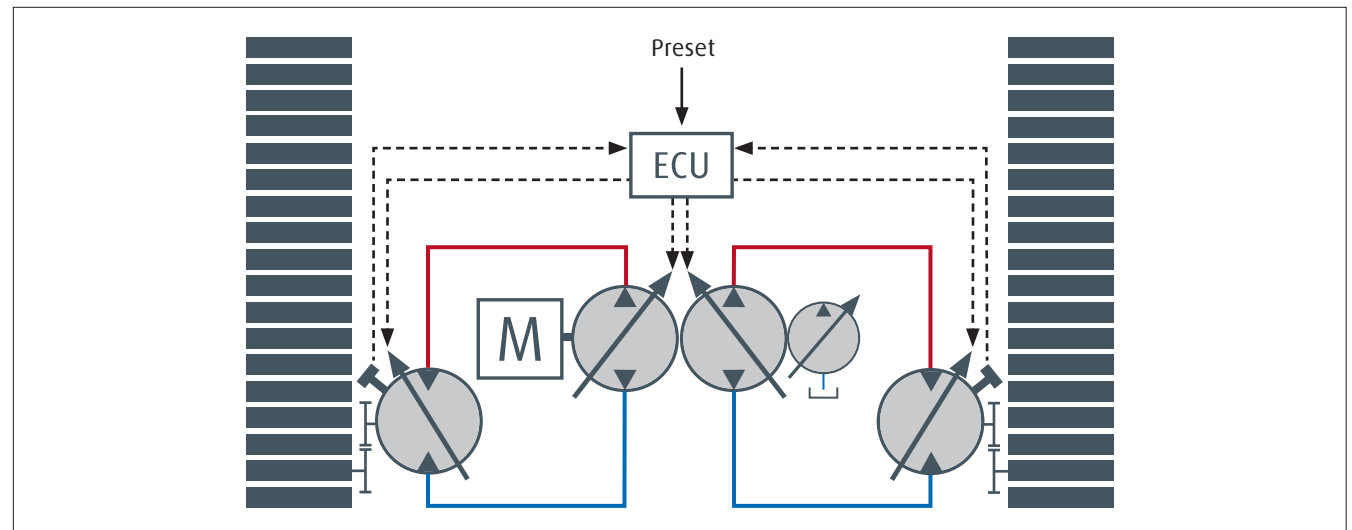

## Equipment

- A** 2x HPV 55-02 E1P
- B** 2x CMV 60 E400
- C** 1x iCon base



# Roller.

## Linde Standard Product Portfolio

10 t - 25 t

### Application Example

15 t

### Equipment

- 1x HPV 105-02 E1 (travel circuit pump)
- 1x HPV 55-02 E5 (pump for vibration)
- 1x CMV 115 E400 (motor at the rear axle)
- 1x HMV 75-02 (motor at the binding)
- 1x CMV 60 E400 (motor for vibration)
- 1x iCon base (electronic control unit)

### Advantages

- High compression power and compacting quality, even with a small number of passes
- Eases the operation for the driver
- Automatic traction control thanks to torque transfer

### Options

- Decentralized design with two wheel motors, so that the engine can be positioned lower, which allows a lower centre of gravity

Even, jolt-free starting, driving and rolling set all Linde drive units apart. The key feature of the drive unit in the compactor in this example is the hydraulic traction control. The compactor boasts two hydraulic motors connected in parallel. One of these drives the rear axle, while another rotates the binding.

The system is able to complete its functions with very little input. Only a single pressure sensor monitors the drive pressure in the drive train. A tilt angle sensor is not necessary for the system to function. The more the drive resistance increases, either due to higher speeds, rougher terrain, or gradients, the more the pressure increases in the drive circuit of the machine. A pressure sensor detects this and reports the status to the electronic control unit, which sends a control signal to the motors.

When accelerating and driving on slopes, the transferable torque moves to the rear axle. The motors are adjusted accordingly and continuously shift a higher percentage of torque from the front to the rear axle – i.e. the axle with the better traction.

In coasting mode, the drive torque is distributed to the binding to benefit the front axle. This generates increased supporting torque, which allows the machine to move in a controlled manner. The drive on the rear axle is increasingly relaxed to maintain good steering properties.

Thanks to the rapid response time of the controller and motor, this all happens very evenly and without any interruption of tractive effort. The driving speed remains constant. The operator does not have to intervene manually and can concentrate fully on the task of achieving consistently high compacting quality.

This is further supported by the vibration drive for the binding. The strength and frequency can be set independently from the driving speed.

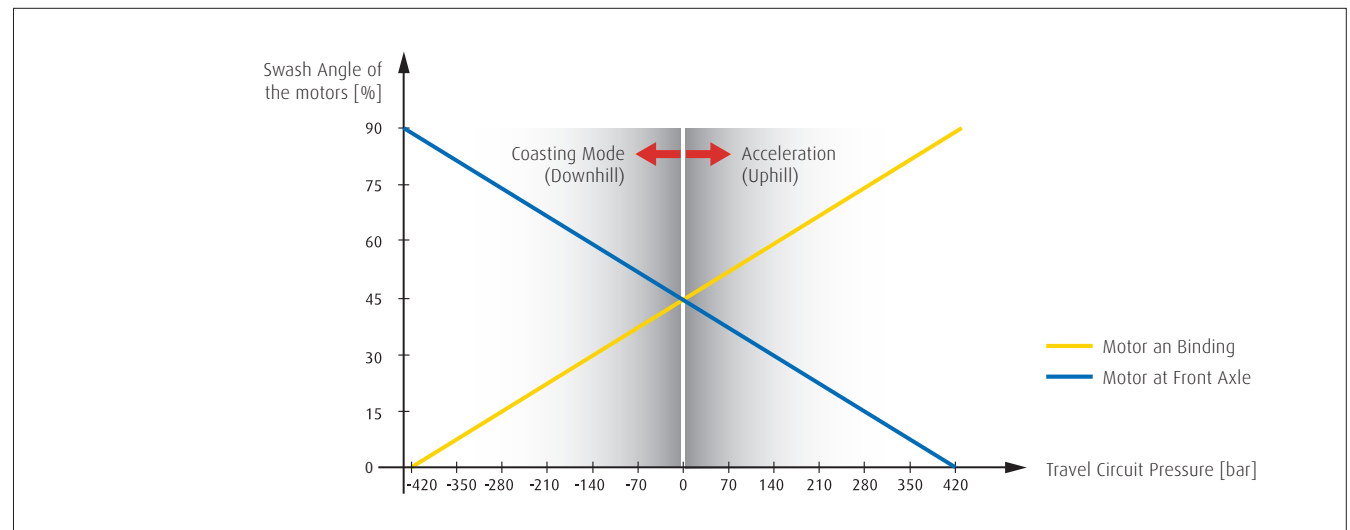

**Equipment**

- A** 1x HPV 105-02 E1 + HPV 55-02 E5
- B** 1x CMV 115 E400
- C** 1x HVM 75-02
- D** 1x CMV 60 E400
- E** 1x iCon base



**Category**



# Material Handling.

## Linde Standard Product Portfolio

20 t - 120 t

### Application Example

120 t

### Equipment

- 1x HPV 210-02 TC (pump for swing drive)
- 2x HMF 135-02 (motors for swing drive)
- 2x HPR 280-02 T E1L (tandem pump)
- 2x VT4 (directional control valves)
- 1x icon base (electronic control unit)

### Advantages

- Rotation independently of the remaining hydraulics system
- Precise rotating mechanism positioning via pre-controlled pump displacement feedback system
- Defined, load-independent and thus reproducible run-out behaviour
- Dosable countering
- The function "Turn in closed circuit" is increasingly beneficial for smaller material handling machines

### Options

- Customer-specific adjustment of the rotating mechanism dynamics - even on site
- Energy recovery from the rotating mechanism
- Stationary material handling machines
- Electric motor as primary drive

Machines that rotate a lot in their day-to-day work, such as the material handling machine shown here, benefit from a slewing gear in a closed hydraulic circuit. This means the rest of the machine can be optimised to the work functions, regardless of the rotating mechanism performance. The configuration shown uses two fixed displacement motors in combination with a variable displacement pump with torque control. This combines a hydraulic proportional flow characteristic with a torque control characteristic. During acceleration, the pump swivels quickly thanks to the volume control and increases the torque in direct proportion to the acceleration setting of the joystick. The torque characteristics of the control dominate the movement. The movement is dynamic but never jerky, even when re-accelerating out of a run-out phase.

The pump control forms the basis for load-independent, customisable run-out of the upper carriage in the neutral position of the joystick. Its position feedback control compensates for load influences.

The mechanically pre-set run-out behaviour of the upper-carriage when the joystick is in the neutral position is the same for every boom distance and clamshell load. During countercontrol, the run-out angle can be reduced additionally in a dosed manner. This transfers the core features of the LinDrive driving experience to the working hydraulics system: precision, dynamics and reliability with unrestricted machine control.

The system is supplemented by the open circuit as a dual circuit setup. As such, significant lifting power can be achieved regardless of the swing movement. A self-regulating pump tandem and two valve blocks efficiently serve the different energy levels of the remaining actuators. The result is a dynamic machine that is easy and sensitive to operate for very high material handling performance with minimal loss, which does not cause fatigue.

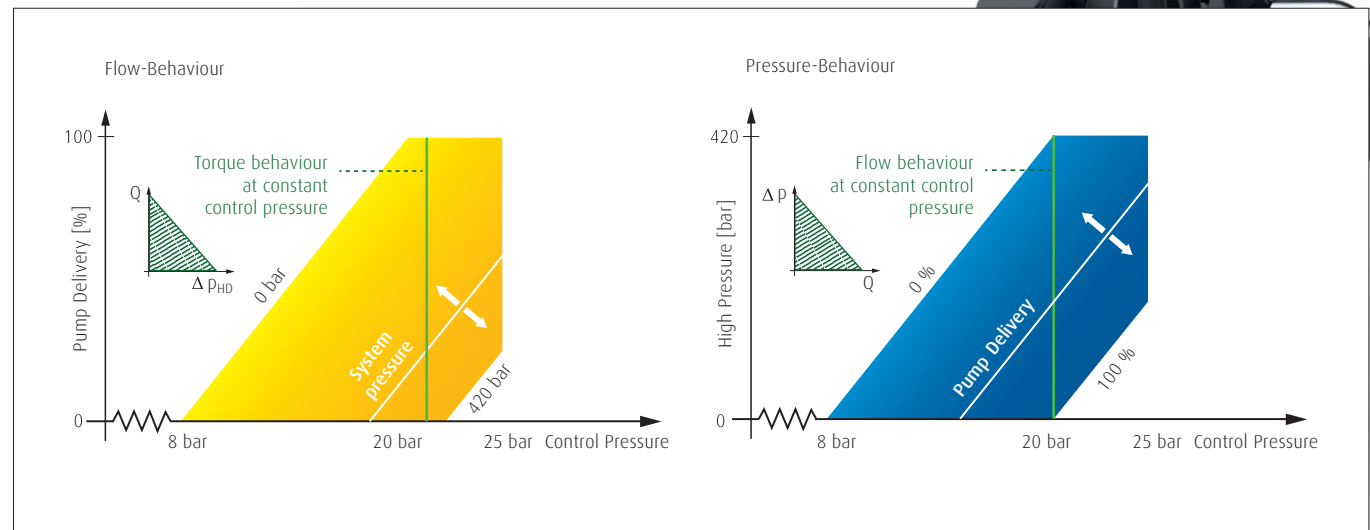



### Equipment

- A** 1x HPV 210-02 TC
- B** 2x HMF 135-02
- C** 2x HPR 280-02 T E1L
- D** 2x VT4
- E** 1x iCon base

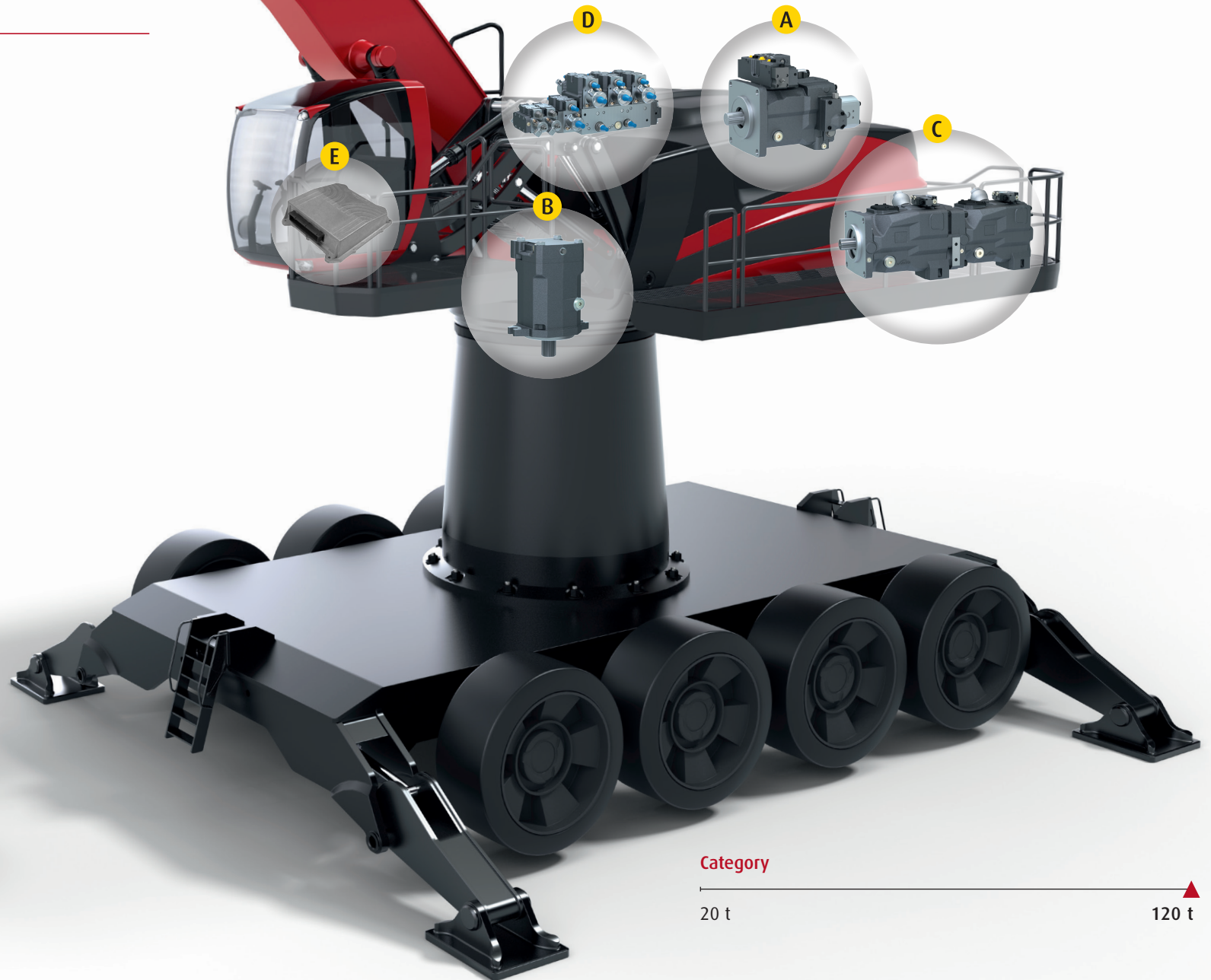

### Category

20 t

120 t

# Concrete Pump.

## Linde Standard Product Portfolio

15 m - 70 m

### Application Example

55 m

### Equipment

2x HPV 210-02 E1P fast swiveling  
(conveying pumps)

1x HPR 55-02 LP (working hydraulics pump)

1x iCon base (electronic control unit)

### Advantages

- Exact synchronisation of the pumps
- Good filling degree of the cylinder
- High conveying speed
- Low mast vibrations
- Robust hydraulic units
- Low noise emission

High and steady concrete flow characterizes a premium concrete pump. It benefits from the smooth running behaviour of the Linde components, which help to reduce mast vibrations and noise emissions to a minimum. The assembly realizes up to 36 conveying cycles per minute which results in an almost constant concrete flow. The two conveying cylinders are driven by two HPV variable displacement pumps, which operate in a push-pull mode. Each pump features 210 cc/rev displacement and is optimized to this application. This is done by an optimized signal flow and an increased control pressure of 40 bar which enables the pumps to swivel between the two displacement maxima in only 210 ms. This makes them one of the fastest pumps on the market in this scale.

By operating in a closed hydraulic circuit, the system only needs a small amount of circulating oil. Like every controller available for the HPV, the E1P type represented here is working independent of the load. Since the control signal for the pump is always the same, there is no need to change the software in order to adapt the machine to different conveyor heights or different concrete textures.

The other components of the open hydraulic circuit are fed by a HPR 55-02 self-regulating pump which is also very silent due to its pulsation damping SPU unit.

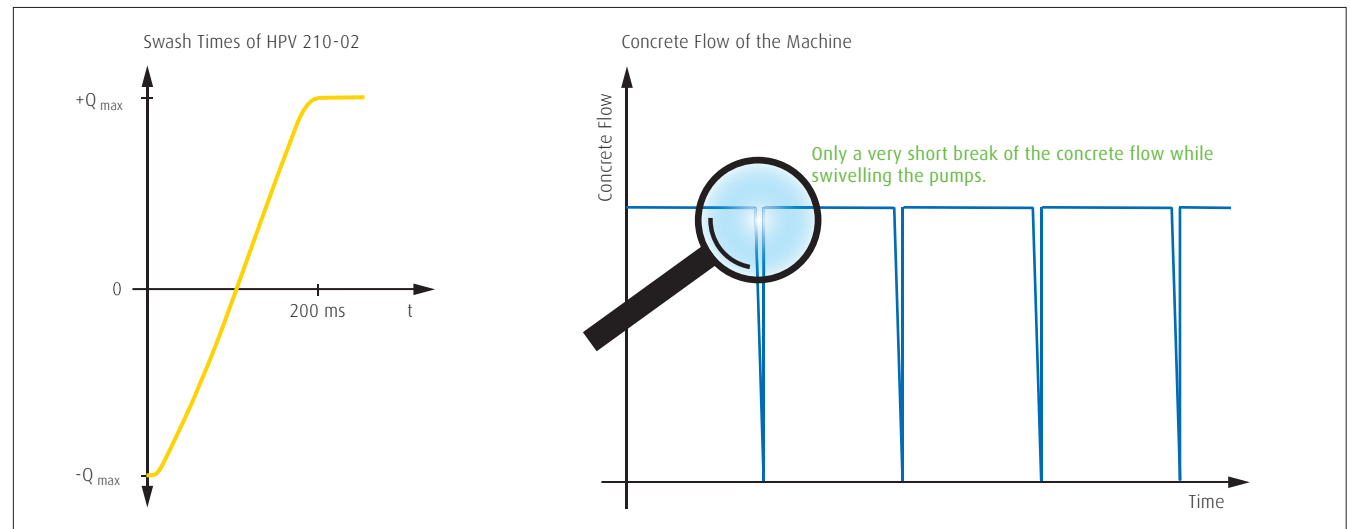

### Equipment

- A** 2x HPV 210-02 E1P
- B** 1x HPR 55-02 LP
- C** 1x iCon base



Boom Length



# Crusher.

## Linde Standard Product Portfolio

200 t/h - 800 t/h

### Application Example

450 t/h

### Equipment

1x HPV 210-02 E1 (pump)

2x HMA 280-02 (tandem motor)

1x VD18 (crossover relief valve block)

### Advantages

- High conversion range
- Simplified drivetrain
- Robust units with excellent control dynamics
- High torque and comparatively high speeds

### Options

- Motors can be actuated individually
- Both motors can be swivelled to 0 cc/rev

The key feature of Linde series 02 high-pressure motors is that they have a PTO drive shaft thanks to the swash plate design. This means that two or more motors can be combined in tandem. With an identical gearbox interface and the same rotating speeds, they offer twice the displacement and therefore twice the torque and power. Compared to individual motors with identical nominal sizes, they have smaller dimensions and higher potential speeds, even compared to bent-axis motors. The rear motor also has a PTO option, which means the tandem motor can be directly integrated into the drivetrain or a speed sensor can be fitted. An electronic control unit actuates the motors and the pump and offers electronic maximum load regulation of the drive motor.

The crossover relief valve is the ideal supplement for the tandem motor. It allows rapid limitation of the high pressure in the motor, which reduces the load for the remaining hydraulics circuit. It offers additional ports for connecting the rear motor, which reduces the amount of piping in the machine.

Above all, the semi-stationary crusher shown here benefits from the robust design of the motors and the high torque. The result is continuously high crushing performance with long durability.

The hydraulic components are not only powerful and robust, but also allow fast, infinitely variable control. As such, the crusher can be adjusted perfectly to the required material, producing consistent results every time. The system can be reversed quickly if there is a blockage in the crushing chamber.

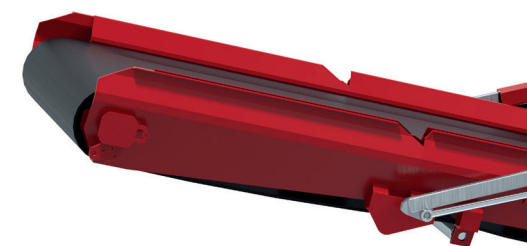

## Equipment

- A** 1x HPV 210-02 E1
- B** 2x HMA 280-02 + 1x VD18

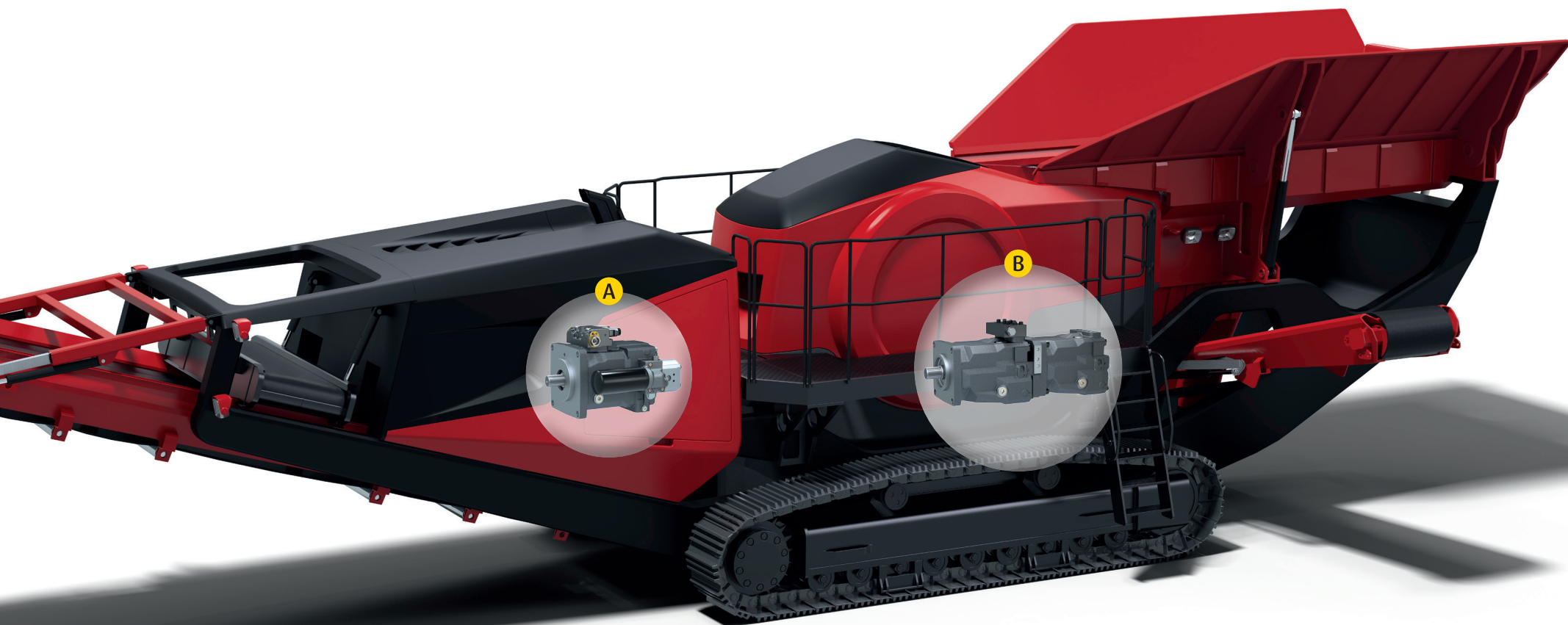

## Throughput

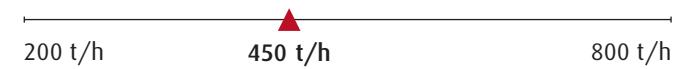

# Mining Rail.

## Equipment

1x HPV 210-02 CAF (Pump)  
6x HMV 75-02 E6 (Motors)

## Advantages

- Does not require electronics
- Maintains constant speeds precisely
- Excellent continuity of movement
- Good availability

## Options

- Freely selectable charge pump
- One CA module, even for several drive pumps in different railcars

Machines that are primarily used for driving and transport benefit most from the unrivalled feel of LinDrive. When used in the mining locomotive shown here, a drive unit in a closed hydraulic circuit with a diesel speed-dependent pump displacement CA is recommended. This offers a high safety standard for driving and stopping due to a reliable pump neutral position when idling and due to activation and shut-off of the control signal at defined diesel speeds.

The high setting forces in the pump controller ensure precise control in any operating mode. After smooth starting, the pump goes on stroke without delay and the drive accelerates the vehicle dynamically with optimum utilisation of the installed power. During deceleration, the drive is supported by the diesel, generating a continuous, moderate retardation through to standstill. In order to use slopes, the motors and the pump can be swivelled to zero. In the event of unwanted rolling back, even a minor speed increase returns the machine to a standstill and subsequent fine-touch driving. The configuration shown here

uses several motors in order to set the hydraulic power in motion. These ensure high climbing capability with full loads and higher speeds with empty loads. A CAF block, which governs the diesel speed dependency of the pumps, can also control several pumps, which means that longer trains with multiple railcars or more motors are possible.

The choice of motor type depends on the required vehicle characteristics. Using regulating or variable motors with or without pressure regulation affects the drive characteristics accordingly. High levels of robustness and long service life are therefore guaranteed for each configuration thanks to the proven construction qualities and excellent qualities of the series 02.

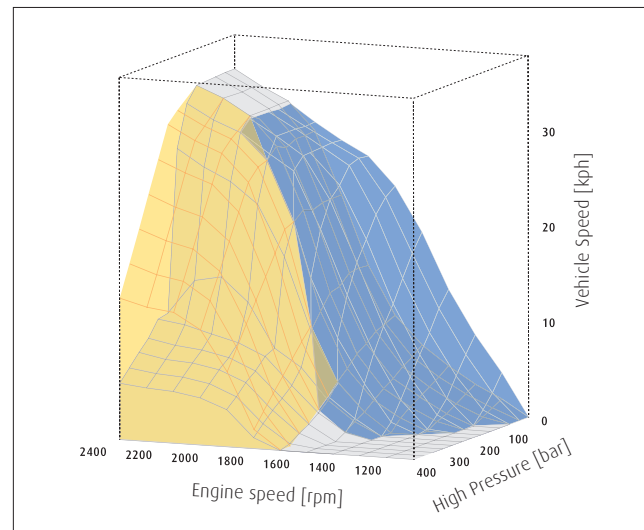

- With Variable Motor HMV-02 EH1P CA
- With Self-regulating Motor HMR-02
- With Variable Motor HMV-02 ohne Druckregelung

## Equipment

---

**A** 1x HPV 210-02 CAF

**B** 6x HMV 75-02 E6



# Telehandler.

## Linde Standard Product Portfolio

5 t - 15 t

### Application Example

7.5 t

### Equipment

1x HPV 55-02 E2 (pump for travel circuit)

1x HMV 105D-02 E6 (motor for travel circuit)

1x iCon base (electronic control unit)

### Advantages

- Reduced components and weight reduction (approximately 33%) thanks to the lack of transfer box and manual gearbox
- More design space and better centre of gravity thanks to the direct installation in the drivetrain
- No interruption of tractive effort
- Cost reduction in the drivetrain and radiator

### Options

- Purely hydraulic or fully-electrified system
- Customer-specific assembly points
- Decentralized layout with individual motors per axle

The key feature of the telehandler configuration shown here is the hydraulic mechanical drive with our innovative double motor. This delivers maximum tractive effort even at minimal diesel speeds. Thanks to the through drive shaft, it can be installed if required between the cardan shafts or with one side directly towards the drive axle. The immediate power transmission ensures excellent drive and allows fast reversing, fine-touch driving, and precise shunting. Smooth at all times, even when heavily loaded.

The lack of a gearbox reduces costs, increases overall efficiency, allows a smaller radiator and eliminates gear noises. The driver is free at all times to give his full attention to the load being moved.

The axial piston double motor design offers higher maximum speeds and hence a bigger transmission ratio spread of oil volume flow into rotary motion than conventional swash plate motor designs. The HMV 105D is about 30 percent lighter than a motor with transfer gear box and is shorter than other modular approaches. This is achieved through innovative design of two

in-line swash plate rotating groups in "face-to-face" arrangement. This means that only one swash plate is needed to adjust the displacement volume of the two motors, and additionally inner lateral forces are compensated so that only one drive shaft and only two (instead of four) bearings are required for both rotating groups. Apart from the weight and size advantages, the double motor also offers cost reductions in the drive-train with full power take-off capability.

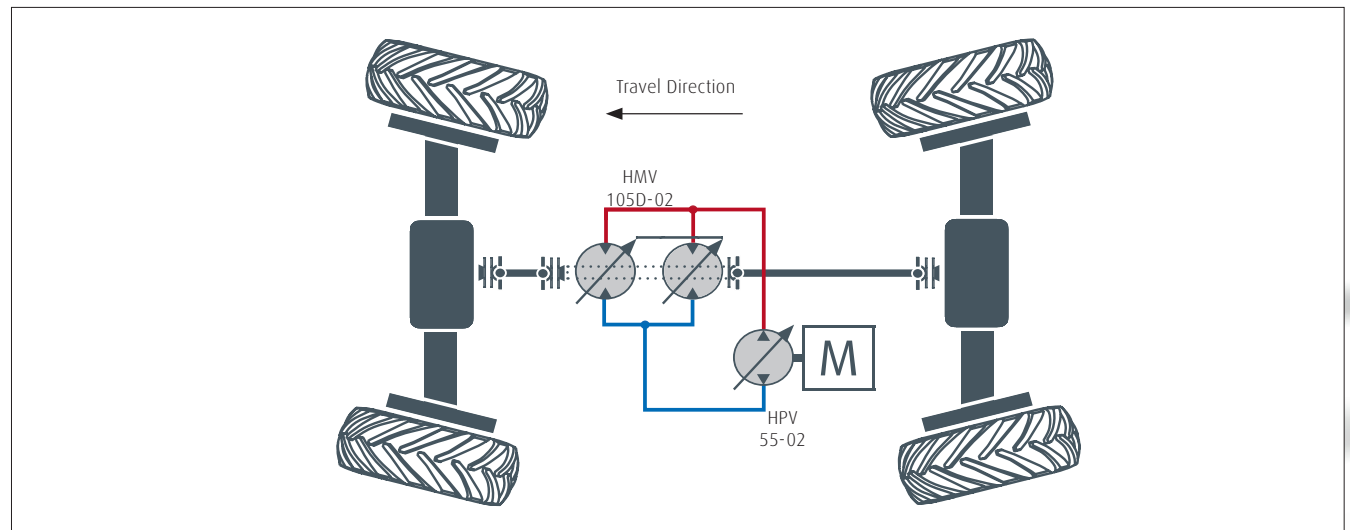



## Equipment

- A** 1x HPV 55-02 E2
- B** 1x HVM105D-02 E6
- C** 1x iCon base



## Category

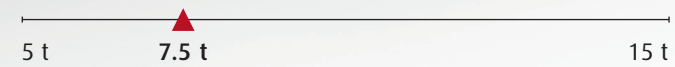

# Well informed. Our current Media at a Glance.

## Internet

Our website [www.linde-hydraulics.com](http://www.linde-hydraulics.com) gives you an up to date overview of the company and its products. In addition to that you will find videos and animations. In the download area we provide selected CAD models and drawings to help you with installation studies. The following print media are available in the latest version, optimized for screen resolution.

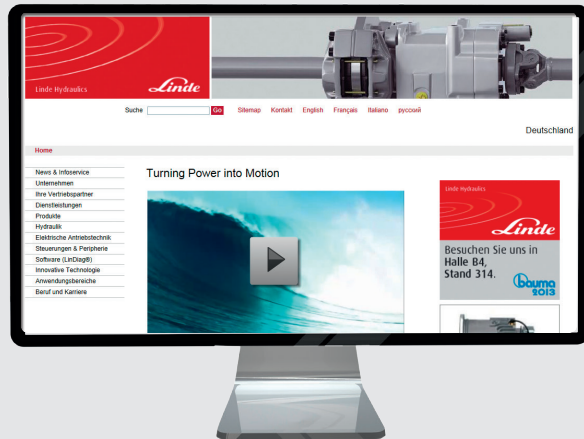

## Product Catalogue and Brochures

The product catalogue presents the company Linde Hydraulics and provides an overview of the entire portfolio. The brochures highlight single areas of the broad and interesting application spectrum of the components and systems.

### Product Catalogue

- 1 Turning Power into Motion.

### Brochures

- 1 Drive systems for construction machines.
- 2 Drive systems for agricultural machines.
- 3 HPV-CA. Unbeatable driving experience for applications with engine speed control
- 4 LSC Linde Synchron Control. Performance meets Flexibility
- 5 VW M3. LSC directionale control valves in monoblock design.

## Data Sheets and Fact Sheets

Data sheets offer a more detailed view of the specific product group. The emphasis is on technical data and hints for the proper configuration of the specific unit. Fact Sheets offer a quick overview about a specific product.

### Data Sheets

- 1 HMF/A/V/R-02. Hydraulic Motors for Closed and Open Circuits
- 2 HPR-02. Self-regulating Pumps for Open Circuits
- 3 HPV-02. Variable Displacement Pumps for Closed Circuits
- 4 VT modular. LSC Manifold Valve Plates

### Fact Sheets

- 1 CMV. Variable Displacement Bent Axis Motor
- 2 CMF. Fixed Displacement Bent Axis Motor
- 3 HMV-02D. Variable Displacement Double Motor
- 4 Shift in Motion
- 5 VW 18 M3. Monoblock control valve

**1**

**Turning Power into Motion**  
modulare hydraulische und elektrische Antriebstechnik

**1**

**Antriebsysteme für Baumaschinen**

**2**

**Antriebsysteme für Landmaschinen**

**1**

**HMV A7/8/02**  
Hydraulikmotoren für den geschlossenen und offenen Kreislauf

**2**

**HMV-02**  
Hydraulikmotoren für den offenen Kreislauf

**1**

**CMV Variable-Displacement**  
Best aus motor

Parameter	Value
Max. Drehmoment	1000 Nm
Max. Drehzahl	2500 U/min
Max. Leistung	25 kW
Max. Volumenstrom	100 l/min
Max. Druck	350 bar
Max. Temperatur	60 °C
Max. Viskosität	150 cSt
Max. Viskositätsbereich	30 - 150 cSt
Max. Schweißleistung	100 A
Max. Schweißspannung	20 V
Max. Schweißgeschwindigkeit	10 mm/min
Max. Schweißtiefe	10 mm
Max. Schweißbreite	10 mm
Max. Schweißhöhe	10 mm
Max. Schweißdicke	10 mm
Max. Schweißlänge	10 mm
Max. Schweißbreite	10 mm
Max. Schweißhöhe	10 mm
Max. Schweißdicke	10 mm
Max. Schweißlänge	10 mm

**2**

**CMV Fixed-Displacement**  
Best aus motor

Parameter	Value
Max. Drehmoment	1000 Nm
Max. Drehzahl	2500 U/min
Max. Leistung	25 kW
Max. Volumenstrom	100 l/min
Max. Druck	350 bar
Max. Temperatur	60 °C
Max. Viskosität	150 cSt
Max. Viskositätsbereich	30 - 150 cSt
Max. Schweißleistung	100 A
Max. Schweißspannung	20 V
Max. Schweißgeschwindigkeit	10 mm/min
Max. Schweißtiefe	10 mm
Max. Schweißbreite	10 mm
Max. Schweißhöhe	10 mm
Max. Schweißdicke	10 mm
Max. Schweißlänge	10 mm

**3**

**Unschlagbares Fahrgefühl**  
für Maschinen mit Grunddrehzahl-Steuerung

Spezialbauweise: Ballast, Heißluft, Dampfer

**4**

**Performance meets Reliability**  
LSC: Linde Synchron Control

**3**

**HMV-02**  
Hydraulikmotoren für den geschlossenen Kreislauf

**4**

**VT modular**  
Antriebsystem für LSC-Synchronsteuerung

**3**

**HMV-02 D**  
Variable-Displacement  
Best aus motor

Parameter	Value
Max. Drehmoment	1000 Nm
Max. Drehzahl	2500 U/min
Max. Leistung	25 kW
Max. Volumenstrom	100 l/min
Max. Druck	350 bar
Max. Temperatur	60 °C
Max. Viskosität	150 cSt
Max. Viskositätsbereich	30 - 150 cSt
Max. Schweißleistung	100 A
Max. Schweißspannung	20 V
Max. Schweißgeschwindigkeit	10 mm/min
Max. Schweißtiefe	10 mm
Max. Schweißbreite	10 mm
Max. Schweißhöhe	10 mm
Max. Schweißdicke	10 mm
Max. Schweißlänge	10 mm

**4**

**Shift in Motion**  
Hydraulische Steuer-Systeme

**5**

**VW M3**  
LSC - Steuerventile in Monoblock Bauweise

**5**

**VW M3**  
Control Valve

Parameter	Value
Max. Drehmoment	1000 Nm
Max. Drehzahl	2500 U/min
Max. Leistung	25 kW
Max. Volumenstrom	100 l/min
Max. Druck	350 bar
Max. Temperatur	60 °C
Max. Viskosität	150 cSt
Max. Viskositätsbereich	30 - 150 cSt
Max. Schweißleistung	100 A
Max. Schweißspannung	20 V
Max. Schweißgeschwindigkeit	10 mm/min
Max. Schweißtiefe	10 mm
Max. Schweißbreite	10 mm
Max. Schweißhöhe	10 mm
Max. Schweißdicke	10 mm
Max. Schweißlänge	10 mm

