

**Operating Instructions**  
Series 02



For Linde axial piston units in open  
loop application.



1	Range of application	4
2	General instructions and safety information	5
3	Environmental aspects	6
4	General hints for fitting and installation	7
5	Mechanical linkage of Linde axial piston units	8
5.1	General hints for mechanical linkage	8
5.1.1	Input and output shafts	8
5.1.2	Cardan/Propeller shafts	8
5.1.3	Additional mechanical power take off (PTO)	8
6	Mounting position	9
6.1	Regulating pump HPR-02	9
6.2	Hydraulic motors HMF/A/V/R-02	9
7	Pipe work	10
7.1	High and low pressure lines, maximum pressures	10
7.2	Suction line of the HPR-02	10
7.3	Venting port, leakage lines and case pressure	10
7.4	Suction line of the ancillary pump	10
7.5	Function diagram (example)	11
8	Hydraulic fluids, temperature and filtration	12
9	Open loop circuit	13
10	Initial start up	14
11	Maintenance	17
11.1	Checking and maintenance points	17
11.2	Test points	17
11.3	Checking points	17
11.4	Exchange of filters	17
11.5	Exchange of hydraulic fluid	17
12	Circuit diagrams (examples )	12
12.1	Hydraulic pump HPR-02 E1L with SPU	18
12.2	Hydraulic motor HMR-02 without counter balance valve	19
12.3	Hydraulic motor HMR-02 with counter balance valve	20
12.4	Hydraulic motor HMF-02 with anti-reaction-valve	21
13	Training	22
14	Contact	23

Read this operating instruction carefully and entirely, and keep it handy for reference. This operating instruction refers exclusively to Linde Series O2 hydrostatic units used in open loop circuits.

- Self-regulating pumps HPR-02
- Variable displacement motors H MV-02
- Regulating motors HMR-02
- Fixed displacement motors HMF-02
- Adjustable fixed displacement motors HMA-02

This document offers information, hints and instructions with regard to safety, effectiveness and life of the above listed hydrostatic units. These refer to the installation in the drive system, commissioning and use of the Linde hydraulic units. Furthermore it contains instructions about the necessary maintenance work.

This operation instruction is intended for experts already experienced in handling hydrostatic systems. Due to the vast variety of applications, it is impossible to deal with all executions of hydraulic pumps and motors within the frame of this document. So whenever application requirements, mounting situations and working conditions or simply uncertainties arise, they must be discussed with the manufacturer of the system on the basis of the following documentation. In case contact with Linde sales or service is needed, you are politely requested to take down the serial number from the name plate of the Linde unit. The name plate always reflects technical status of the unit. Subsequent one standard Linde name plate, as example: HPR 105-02R.



Our products are being developed constantly; so, please understand that we have to reserve the right for changes and no claims whatsoever may be derived from the contents of this operating instruction.

By publishing this edition all previous editions become void.

All rights in this instruction are reserved for Linde Hydraulics GmbH; for internal use however, copies may be produced.

### Technical support

If you have technical questions concerning our products kindly contact the Linde Hydraulics Organisation.

### CAUTION

All valid safety regulations and accident prevention instructions must be adhered to.

The Series 02 axial piston units referenced in this document are designed for application in the industrial field. As state of the art, they have been designed for safe function and manufactured according to the corresponding practices.

In hydraulic drive systems correct component engineering is crucial; also, a professional approach to system design has a direct influence on the components used with regard to their operational properties and in particular to their life expectancy and working reliability.

It is taken for granted that the basic planning for application as well as all work related with transport, assembly, installation, commissioning and maintenance are carried out by qualified personnel and supervised by responsible experts.

#### Special attention is required for:

- Technical data and data about the permissible use (mounting, fitting, surrounding and working conditions) as is contained in product data sheets, installation drawings, spare parts catalogue, order specifications and name plate data.
- General construction and safety procedures
- Rules and requirements specific to the local plant
- Correct use of tools, lifting and material handling accessories.
- Use of personal protection equipment.

#### Braking arrangement

It is absolutely necessary to install a braking arrangement redundant to the hydrostatic braking system. It must be capable of stopping the vehicle out of its travel motion and/or serve as a parking brake. Or even, in the case of stationary applications bring the machine to a stop.

Loss of frictional connection in the drive train of a hydrostatic system in the neutral position, or during acceleration and deceleration may mean loss of hydrostatic braking altogether.

Legal regulations must be adhered to as well, under all circumstances!

### CAUTION

Failure to follow the guidelines of this operating instruction may result in the failure of vital functions, machine damage, danger to health and life of personnel, imperilment to environment, as well as loss of warranty rights with Linde Hydraulics.

 ENVIRONMENTAL CONCERNS

Protection of the natural fundamentals of life is one of our predominant tasks. We are continuously improving the protection of the environment as far as applications are concerned. We encourage you to contribute your share to comply with this demand. In connection with work to be performed, the environmental regulations of the machine manufacturer must be respected.

In general:

- Greases and oils which cannot be used any more have to be collected. They are normally a threat to water reserves and must be kept away from the environment.
- Adhere to national and local regulations for waste disposal.

Installation of the hydraulic system must be completed according to the circuit and piping diagram and the installation requirements of components as well as the technical data sheets and installation drawings. When designing electro-hydraulic circuits, care must be taken that the electrical requirements are respected, e.g. the prescribed voltage is applied to the equipment. For the hydraulic piping seamless drawn precision steel pipes according to DIN EN 10305-4 (ISO 3304) or hoses according to ISO/TR17165-2 of suitable pressure rating must be chosen. Pipes have to be deburred, washed out and blown through. Pipes which have accumulated scale or rust must be steeped and then neutralized; hose lines when contaminated need brushing out and flushing through.

Cleanliness is an important point. The connection ports of hydraulic equipment are, as a rule, closed by the manufacturer with plastic plugs or tape after thoroughly flushing all passages. Cleanliness must be the supreme concern while assembling a hydraulic system. Never plug finished pipes with rags; use plastic foil, tape or plugs instead. Under no circumstances use cloth.

## DANGER

Any amendments, attachments and modifications of hydraulic components possibly with negative effect on safety must not be applied without consulting us.

### 5.1 General hints for mechanical linkage

The mechanical connection of a Linde unit to the drive system is made by its housing flange and the shaft end of its primary input or output.

Linde axial piston units are conceived as plug-on units for coaxial connection to a drive system, i.e. for coupling without radial or angular off-set between driving and driven shaft. The corresponding permissible values regarding the transmissible shaft torque and the effective axial forces are found in the technical data sheet, the installation drawing or the catalogue. Axial forces acting directly on the shaft end of Linde axial piston units are to be avoided. If radial forces are unavoidable for certain reasons, do, under all circumstances talk to us in the early design stage. This applies in particular to cantilevered arrangements of tractive components, e.g. drive belts or chains at the shaft end.

#### 5.1.1 Input and output shafts

In Linde axial piston units of series 02, the shaft ends of the primary input or output are edge centered splines with involute type splines as per ANSI B92.1. The prescribed counter fit of coupling; pinion or pulley must be strictly adhered to. In principle, both during assembly and disassembly input and output elements must not be treated with knocking or beating forces (e.g. hammer blows) on shaft ends of Linde axial piston units, since this will inevitably lead to damage of the drive assembly, particularly of the shaft bearings.

In a drive system made of several components it is usually necessary to dampen rotary oscillations from the prime mover or from the drive train by means of adequate flexible coupling elements. For this case rotary elastic couplings are to be applied which have to be matched to the drive system in their dynamic transmitting properties. In particular it has to be assured that the system stays free of resonance.

#### 5.1.2 Cardan/Propeller shaft

The manufacturer's installation instructions must be followed!

In order to avoid rotary oscillations, keep in mind that both input and output parts of the cardan shaft are fitted under the same angle and on the same level. Only balanced cardan shafts may be utilized and the links must be put together correctly!

#### 5.1.3 Additional mechanical power take off (PTO)

All regulating pumps of Linde's 02 series are equipped with a mechanical power take off as a through shaft at the rear end. This may be used for powering additional drives.

Care must be taken that the permissible torque is not exceeded at any time. For tolerable values please refer to the technical data sheet or catalogue.



In the planning stage of a system and subsequent installation utmost care must be taken that the housing of the hydraulic pump and of the hydraulic motor remain completely filled with fluid after initial filling, venting and in every state of operation. They cannot run empty during operation and temporary or long term stand still. If deemed necessary, additional information regarding the mounting position may be inquired before the system is designed.

### 6.1 Regulating pump HPR-02

Mounting position is horizontal. On designing the suction line, attention must be paid to a straight, short run largely avoiding bends. The hydraulic fluid must have a positive head. Arrangement above tank must be agreed to by Linde hydraulics. The maximum allowed input speed is also directly dependent on the suction pressure. See diagram.

#### HPR-02 suction speed

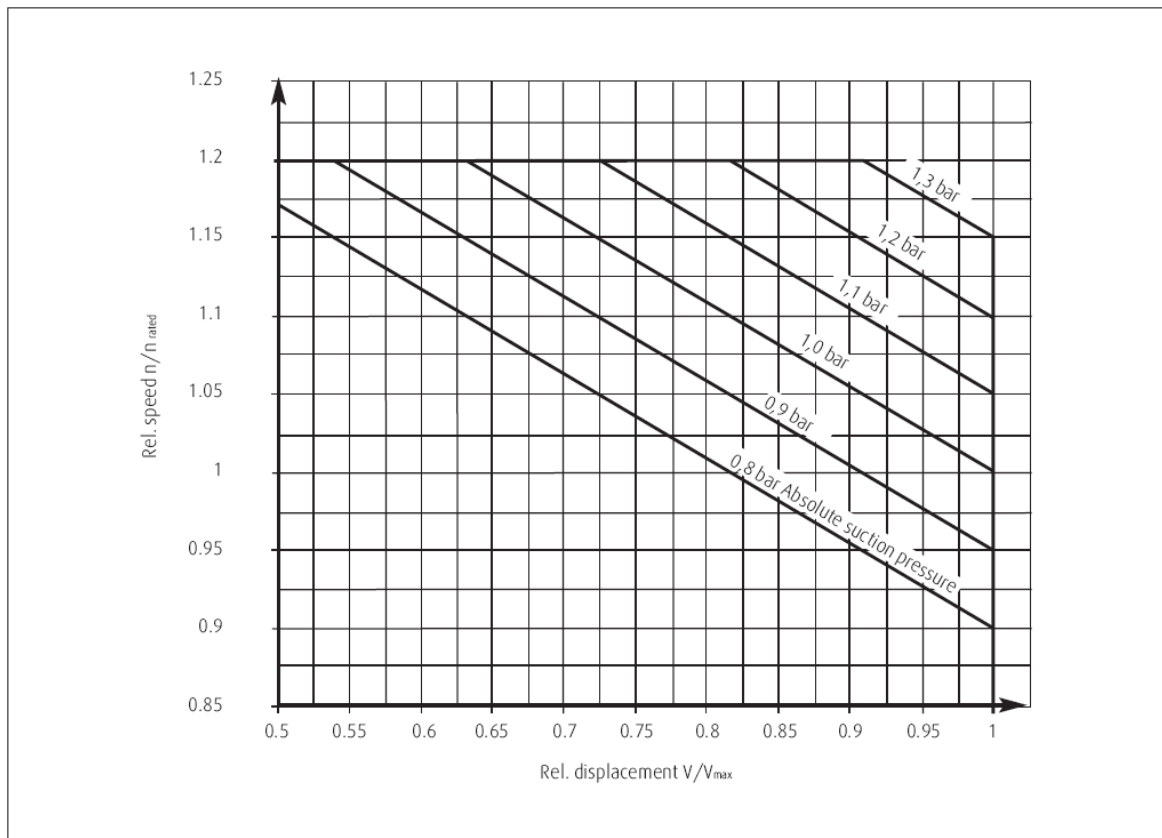

### 6.2 Hydraulic motors HMF/A/V/R-02

Any position is okay, except when the drive shaft points vertically upwards. This requires special measures because of the risk of shaft bearing and shaft seal running dry. A modified version which tolerates this position is available upon inquiry.

### 7.1 High and low pressure lines, maximum pressures

Ensure that hoses, pipes and fittings are of sufficient strength with regard to bursting. In regards to operational reliability, it is important to keep in mind the maximum permissible pressures at the connection point of working and auxiliary ports of the Linde units.

### 7.2 Suction line of the HPR-02

On designing the suction line attention must be paid to a straight, short conduct largely avoiding bends. If bends are required, the bending radius must be as large as possible. The suction boss in the hydraulic tank must have the largest section with a gradual transition and the pump suction flange must have the smallest boss section. Any on/off valves must not reduce the inner diameter. The suction line itself must be installed in such a way that it ends more than  $\geq 100$  [mm] above the tank bottom. In order to enlarge the entry diameter of the suction boss in the hydraulic tank, its end must be cut under  $45^\circ$ . The distance between entry and oil surface must be large enough to avoid air suction, recommendation  $\geq 200$  [mm]. The suction line must be made of suction hose or similar composite needs to be used. Take care of the tightness of the pipe/hose so that air is not drawn in.

### 7.3 Venting port, leakage lines and case pressure

Case drain lines must be installed in such a way that the housings of the hydraulic components are always filled with fluid. At least one of the two connection ports "L" or "U" of the pump/motor housings must be connected to the tank. As a rule drain lines have to be kept separate from the main return line. The drain line has to enter the hydraulic tank below the oil level. All leakage and bleed lines must not be reduced in cross section and must be enlarged accordingly when connecting. The dimension must be ample enough that even at low temperatures the return flow pressure of the leak oil will be near zero. The case pressure (build-up) should not rise and stay higher than 2.5 bar (absolute) during operation.

If during the prototype development and while warming up from a cold start, a higher pressure is found intermittently, this may be accepted as long as it is discussed with Linde.

### 7.4 Suction line of the ancillary pump

The installation of the suction line must be as straight and as short as possible avoiding bends. The piping itself has to be rated in such a way and the tank positioned so, that the maximum permissible negative head of -200 [mbar] at suction port can be achieved.

## CAUTION

We explicitly emphasize that operation of Linde axial piston units with the housing insufficiently filled with fluid will immediately damage the drive system. Therefore check the installation of the Linde unit in the hydraulic system to ensure the case(s) are filled prior to startup.

### 7.5 Function Diagram (Example)

Hydraulic components in the open loop circuit:

- Hydraulic pump HPR-02 E1L
- Hydraulic motor HMF-02
- Control valve block VT with LSC directional control valves

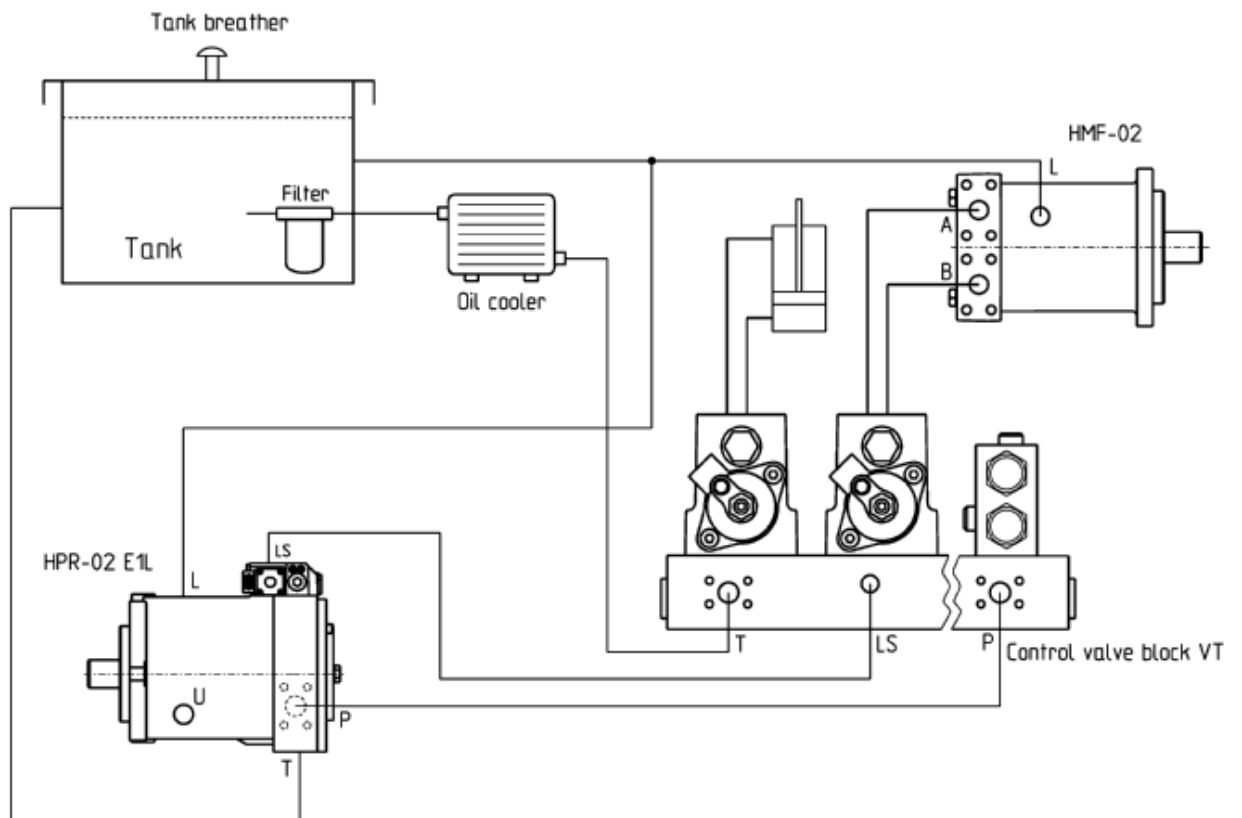

EXPLANATION	
Hydraulic pump HPR-02 E1L	
P	High pressure ports
T	Suction port
LS	Load Sensing port
L, U	Filling, vent and leakage ports. Pump housing must be always filled with oil.
Hydraulic motor HMF-02	
A, B	High pressure ports
L, U	Filling, vent and leakage ports. Motor housing must be always filled with oil.
Control valve block VT	
P	High pressure port for the hydraulic pump
T	Tank pressure port
LS	Load Sensing port

## Acceptable fluids

- Mineral oil HLP according to DIN 51524-2
- Biodegradable oils according to ISO 15380 upon request
- Other hydraulic fluids upon request

## Technical data

Pressure fluid temperature range	[°C]	-20 to +90
Working Viscosity Range	[mm <sup>2</sup> /s] = [cSt]	10 to 80
Optimum Working Viscosity	[mm <sup>2</sup> /s] = [cSt]	15 to 30
Max. Viscosity (short time start up)	[mm <sup>2</sup> /s] = [cSt]	1000

## Viscosity Recommendations

Working temperature [°C]	Viscosity class [mm <sup>2</sup> /s] = [cSt] at 40 °C
30 to 40	22
40 to 60	32
60 to 80	46 or 68

Linde recommends exclusive use of hydraulic fluids for which the manufacturer confirms their suitability for high pressure hydraulic systems. Knowledge of operating temperature in the circuit is a precondition for the right choice of fluid. The choice of hydraulic fluid should be made in such a way that operational viscosity at operational temperature stays in the optimum range (see table above). The Linde hydraulic system must not be operated in viscosity range < 10 [mm<sup>2</sup>/s]! Leakage oil temperature is influenced by pressure and rotating speed and is always above circuit temperature. The temperature should not be above 90°C at any point of the system. If it is not possible to adhere to the above conditions for any reason, you are requested to contact us.

## CAUTION

Mixing mineral oils with bio-type oils is always forbidden.

## Filtration

In order to ensure functionality of the hydraulic components and their high efficiency, it is necessary to select the viscosity class of the working fluid according to ISO 4406:

- Minimum requirements: 20/18/15
- For reliable proper function: 18/16/13 or better
- We recommend for proportional directional control valves: 16/14/11

A high degree of oil purity clearly contributes to prolonging the life expectancy of the hydraulic system. If it is not possible to adhere to the above conditions for any reason, you are requested to contact us.

### The open loop hydraulic circuit

The hydraulic pump used in open loop circuit has two main port connections: One suction port and one high pressure port. The suction port is connected to the hydraulic tank while the high pressure port is connected to the multiple directional control valve block.

When the HPR-02 is driven, it takes oil from the hydraulic tank. The fluid circulation is always from the hydraulic pump to the directional control valve block. From there through the pipes and hoses the fluid is sent to the implements e.g. hydraulic cylinder and/or hydraulic motor.

The flow direction and speed of the fluid determines the direction of motion and velocity of the hydraulic cylinder as well as the direction of motion and speed of the hydraulic motor.

Return oil from the cylinder/motor returns to the directional control valve block and as a rule from there through the oil cooler, filter and back to the tank. Hydraulic pumps and motors always have filling, venting and drain ports in addition to the main ports.

The leakage oil of the components is sent separately back to tank.

If the hydraulic tank is not pressurized, to avoid contamination out of the air, a breathing filter must be installed to avoid contamination from the air.

### Circuit diagram (example)

Hydraulic components in the open loop circuit:

- Hydraulic pump HPR-02 E1L
- Hydraulic motor HMF-02
- Control valve block VT with LSC directional control valves

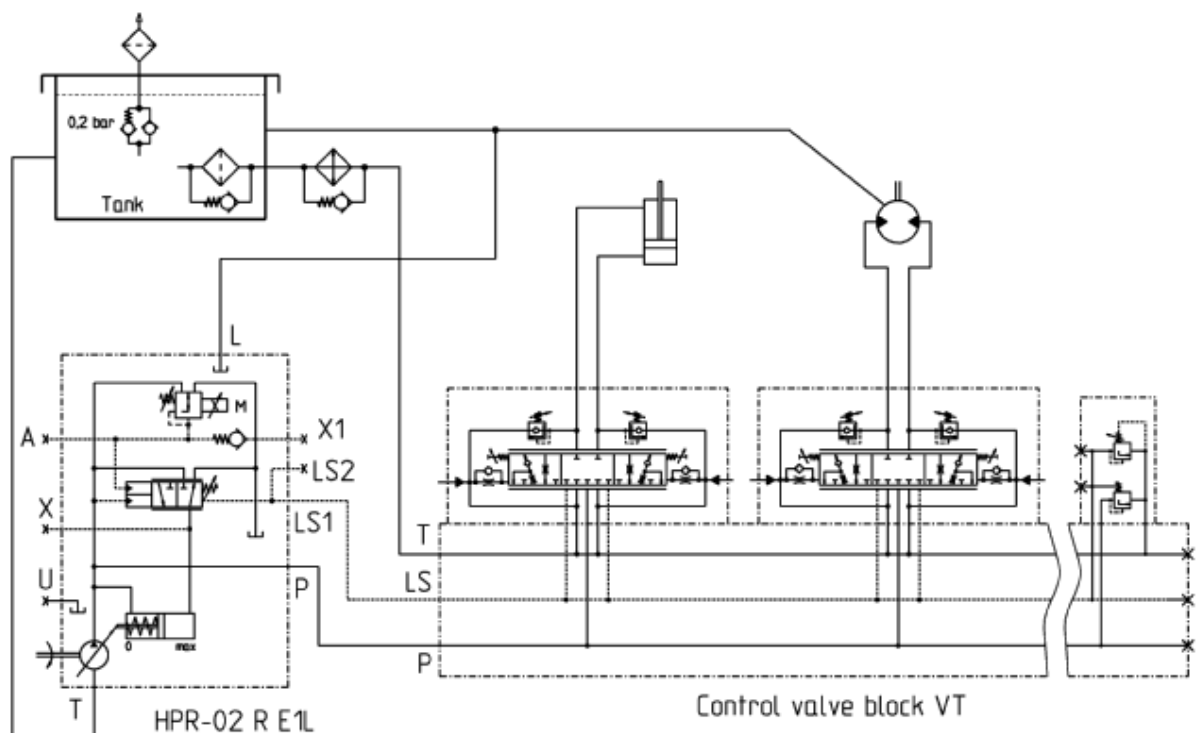

Read operational instructions carefully and thoroughly before you begin with start up. Professional and careful start up is the prerequisite for trouble-free operation and optimum life expectancy!

Additionally we recommend adhering to the following standards  
ISO 4413 "Fluid engineering - design guidelines hydraulics"

### Cleanliness

Oil reservoir and installation have to be checked again for cleanliness before the hydraulic medium is added. This procedure has to be performed immediately before pouring takes place. It may even be expedient to flush the entire installation! Make sure that the pressure fluid corresponds to the required grade of cleanliness.

### Drive rotation

Before starting the engine make sure that the HPR-02 pump will be driven with the correct direction of rotation. With electric motors, it must be checked that the electrical connections are correct. The electric symbol is normally found in the cover of the connector box.

## CAUTION

Under no circumstances start the engine to check the rotation! If the HPR-02 pump is driven against its specified rotation, the drive group will instantly be damaged (initial damage) due to the lack of lubrication. This may result in total break down.

### Initial filling of the hydrostatic transmission

Before starting the prime mover, it must be ensured that the housings of the hydraulic components are filled with oil. Before the hydraulic components may be loaded, the entire circuit must be filled and vented. The suction port and the casing of the HPR-02 are not related to each other! Before the hydraulic components may be exposed to load, the entire circuit must be filled and vented. Required gauges and instruments for monitoring the system need to be fitted.

### Filling of the hydraulic system with a filling device

Even new oil fresh from a barrel or a bulk tank, normally corresponds only to purity grade 23/21/18. Therefore we recommend the initial filling to be done with the help of filling device. This unit has to be equipped with a filter of at least the same filter mesh as the main filter element in the hydraulic system.

Filling the hydraulic system without the filling device directly from the barrel or bulk tank may only be performed through the main filter element of the hydraulic system. This filter element must not be removed from its container in the hydraulic tank for quicker filling.

### Initial filling and venting of the entire system

Take care during the filling procedure not to overfill the hydraulic tank. Fill the hydraulic tank up to the middle of the oil level indicator. During the filling procedure loosen the fittings of the leakage lines on the pump and motors. Depending of the hydraulic installation the system fills up automatically. If this is not the case the hydraulic tank can be slightly pressurized  $< 0,2$  [bar] to support the air venting process. Bleed all the hydraulic components and catch and wipe up the escaped fluid. Tighten up the leakage lines. Almost all of the hydraulic system is now filled and vented.

## ENVIRONMENTAL CONCERNS

### Attention

Dump the collected waste fluid according to the prevailing regulations, do not use it again!

## DANGER

### Before starting the engine, remember the following points!

- A. If there is an on/off valve in the suction line, make sure it is completely open.
- B. Disengage the vehicle and secure it against rolling away or jack it up. Safeguard machines according to their nature. Safeguard surroundings of the vehicle. Uninvolved personnel are to be kept at a safe distance at the moment of starting.
- C. If there is a safety lever, keep it in the lock position.

### Initial start-up

**Start drive engine for the first time and leave it running for a few seconds, take care of unusual noises.**

- Engine is running at low idle. The HPR-02 pump runs at no load.
- Electric motors: switch on and after 5 seconds switch off.
- In case of trouble investigate the reason.
- Switch engine off and check fluid level in the tank. Top off if necessary.
- Bleed the hydraulic components and catch and wipe up the escaped fluid.
- Before restarting the engine, check the installation for tightness.

### Start drive engine again, adjust speed at about 1500 min<sup>-1</sup>

- Carry out the functional movements unloaded. Continually monitor pressure fluid level in the hydraulic tank and top off if required.
- Shut off the drive engine
- Before restarting the engine, check the installation for tightness.

**Start drive engine again and run it at maximum speed**

- Carry out the functional movements unloaded. Continually monitor pressure fluid level in the hydraulic tank and top off as required.
- Shut off the drive engine
- Before restarting the engine, check all connections are tight and no signs of leaks.

**Start drive engine again and run it with the maximum speed**

- Carry out the functional movements unloaded as long as the functions of the implements are smooth in motion without erratic movement.
- Having reached the working temperatures load the system and check all functions again.
- Monitor the hydraulic system temperature.
- After the successful initial start up shut off the drive engine.

**Leave the vehicle switched off for about 30 min.** The residual air in the system can escape to the hydraulic tank only when the engine is off!

If after repeated starts of the drive engine and actuation of the implements foam is generated in the hydraulic tank, the cause of aeration must be investigated.

For example: Connections from pipe to hose on the suction line of the HPR-02 pump.

We recommend again checking all fittings and tightening screws of SAE flanges, even when they are not leaking. Tighten them again to the required torque.

** CAUTION**

Both the checking and tightening of the fittings and screws must be done while the system pressure is released and implements unloaded.

**Start up at low temperatures**

This kind of start up is performed in the same steps as described above. Additionally all the hints regarding lower temperature limit and lower viscosity limit must be strictly observed (see chapter regarding pressure fluid, temperature and filtration). All the additional requirements of the machine manufacturer must be met accordingly.

**THE HYDROSTATIC SYSTEM IS NOW READY FOR USE!**



Maintenance of the hydrostatic transmission is confined to exchanging the filter of the hydraulic pump and exchanging the hydraulic fluid

## 11 Checking and maintenance points

### CAUTION

Access to all checking and maintenance points should be considered at the design stage. Difficult access to and poor visibility of maintenance points generally make them hard to clean. Residual dirt may get into systems and assemblies when they are opened up for any reason. Moreover, there is the risk of injury and mishandling.

Simplified service and maintenance save you time and money.

#### 11.1 Test points

- High pressure (HP)
- Low pressure (LP)

#### 11.2 Checking points

- Oil level.
- Dip sticks.

#### 11.3 Maintenance points

- Filters
- Drain plugs
- Magnetic plugs

#### 11.4 Exchange of filters

We recommend exchanging the hydraulic oil return flow filter directly after the initial start-up.

**Further replacements after every 1000 up to 2000 working hours.** Follow the Machine manufacturers recommendations. While replacing the filter care must be taken that no dirt can enter the system. Use only recommended original filters!

#### 11.5 Exchange of hydraulic fluid

**Attention! Use proper handling and storage procedures and material.**

High working temperatures in combination with frequent phases of cooling down at lower ambient temperatures result in water condensation and shorten the change intervals of hydraulic fluid.

The hydraulic fluid applied determines the safety and reliability of the machine operation.

We recommend having an oil analysis taken at given time for oil change.

Comply with the guidelines of the machine manufacturer. Depending on the application, **the hydraulic fluid is to be exchanged after every 1000 to 3000 working hours.**

Proper oil exchange is done by draining all the oil from tank, pump and motor housing. Procedures stated for initial filling are similarly applicable to the change of hydraulic fluid.

12.1 Hydraulic pump HPR-02 E1L with SPU

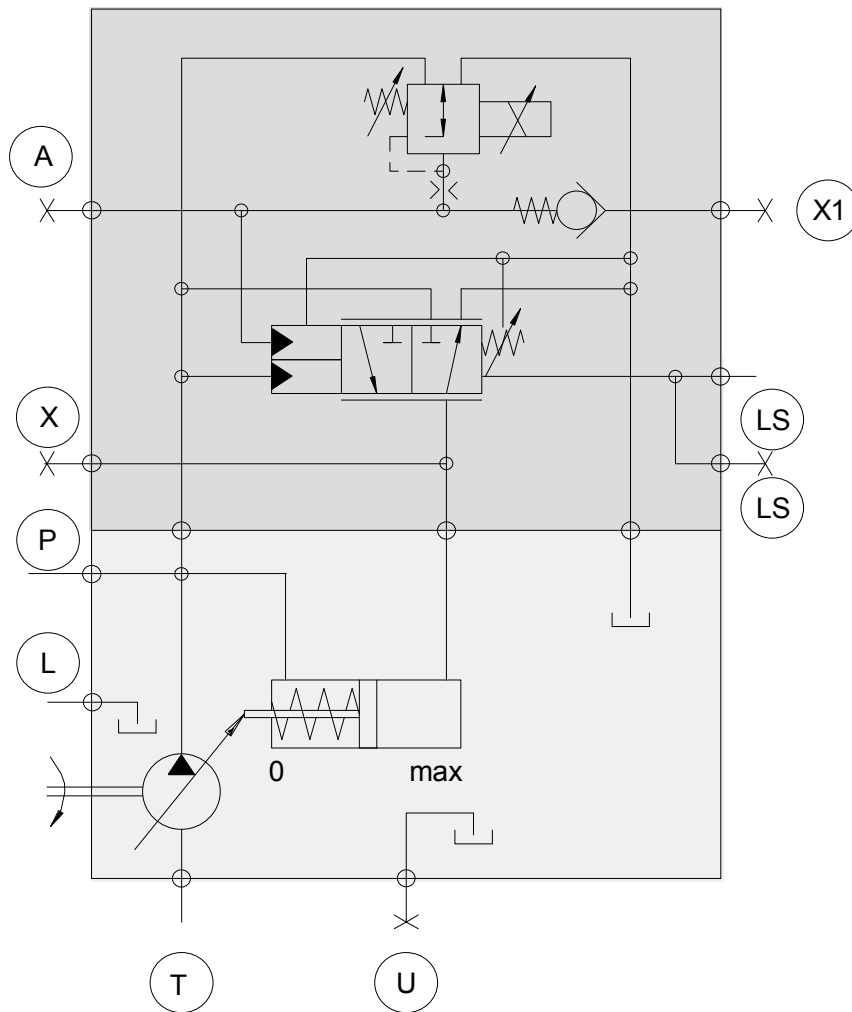
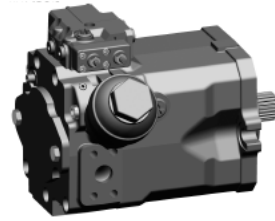

EXPLANATION	
Hydraulic pump HPR-02 E1L	
P	High pressure ports
T	Suction port
LS	Load Sensing port
L, U	Filling, vent and leakage ports. Pump housing must be always filled with oil.

12.2 Hydraulic motor HMR-02 without counter balance valve

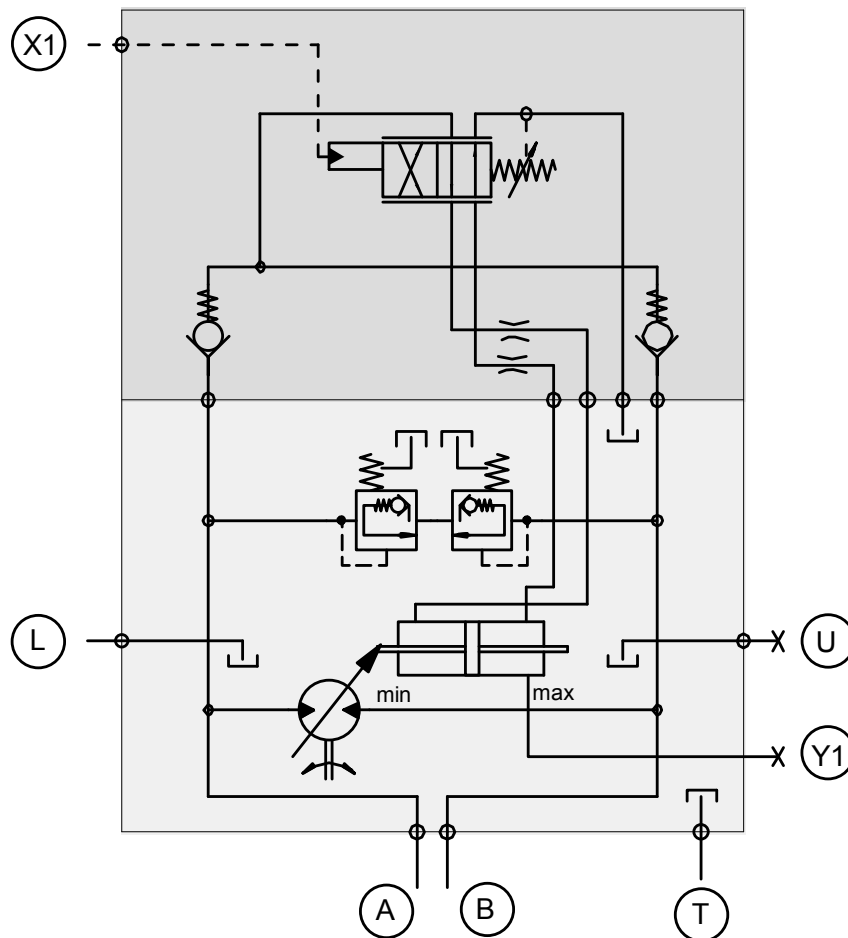
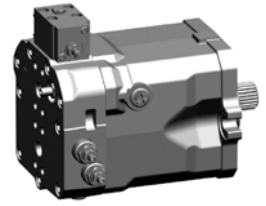

Pressure at B: CCW rotation  
 Pressure at A: CW rotation

EXPLANATION	
A, B	High pressure ports
X1	Control pressure port PX1 20-30 bar
Y1	Gage port, actuating pressure supply
L, U	Filling, vent and leakage ports. Motor housing must be always filled with oil.
T	Tank port for counter balance valve

12.3 Hydraulic motor HMR-02 with counter balance valve

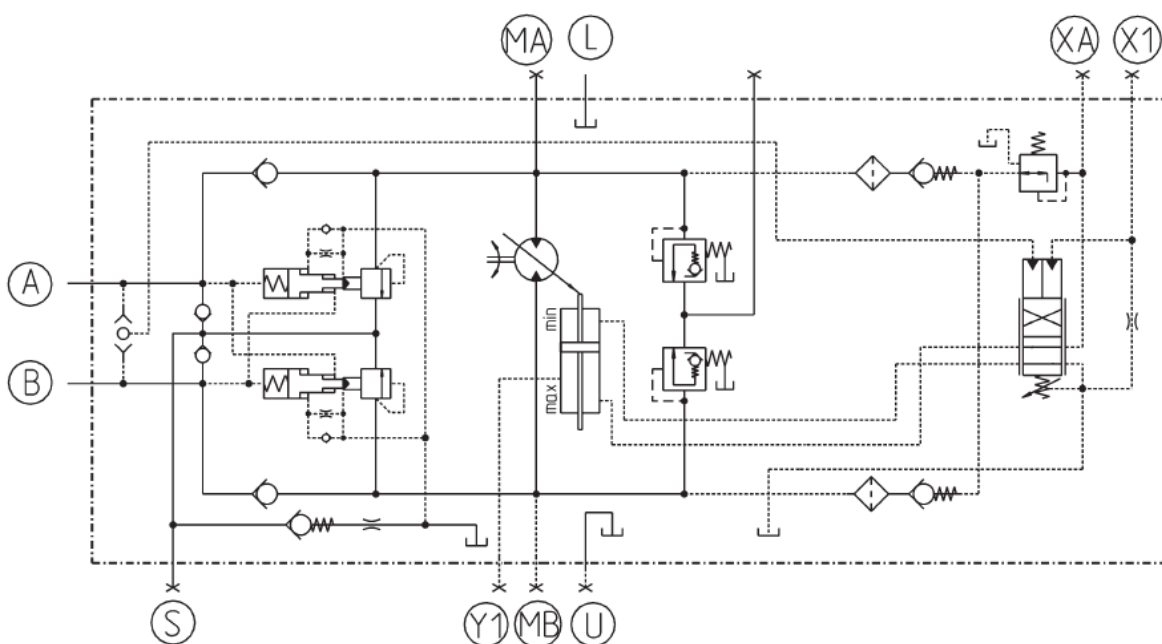
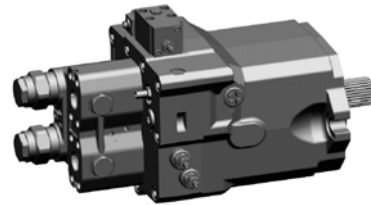

Pressure at A: CCW rotation  
 Pressure at B: CW rotation.

EXPLANATIONS	
A, B	Main pressure ports
X1	Vmax control pressure port px1= 20-30 bar
XA	Gage port, actuating pressure supply
L, U	Drain and leakage ports
MA, MB	Gage ports, high pressure
Y1	Gage port, actuating pressure
S	Charge port (option)

12.4 Hydraulic motor HMF-02 P with anti-reaction-valve

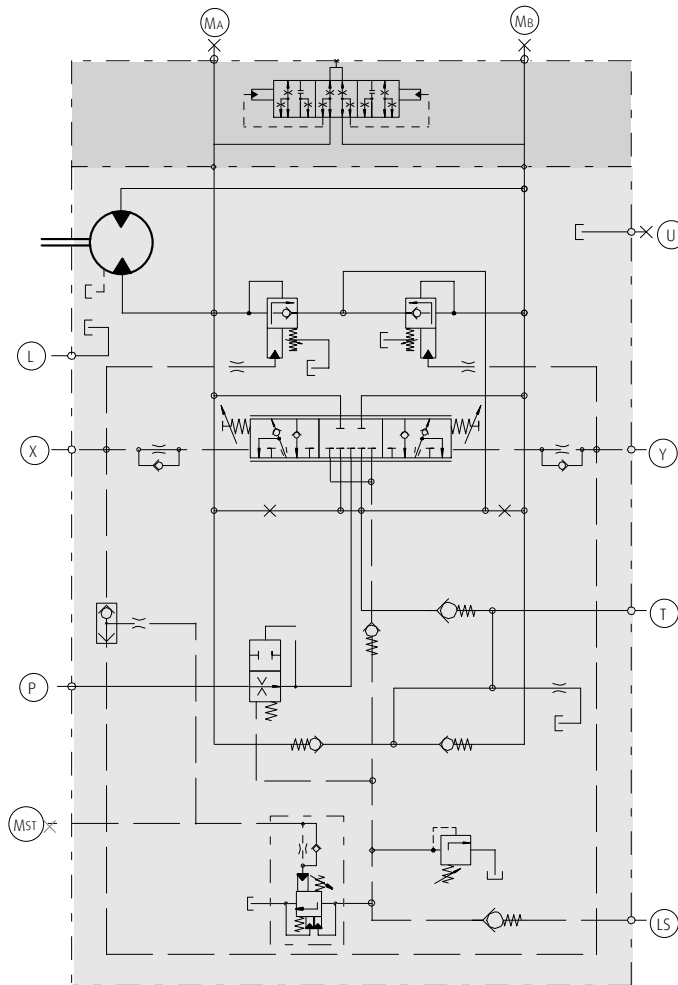
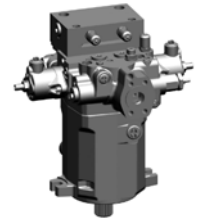

Control pressure in X: CW rotation  
 Control pressure in Y: CCW rotation.

EXPLANATIONS	
P	Pressure port, supply from the main pump
T	Tank
LS	LS pressure port
L, U	Filling, vent and leakage ports
MA, MB	Gage ports, high pressure
X, Y	Control pressure ports
MST	Gage port, control pressure at TC valve

## Training Centre in Aschaffenburg-Nilkheim

In courses on our hydraulic and electronic products we train our customers in the complex hydraulic systems of open and closed loop applications.

The up-to-date training contents result from the experience of our service team and will be oriented to specific customer applications if so desired.

Our competent service team provides quick support to you, worldwide.

## Contact

Volker Kaempf

Training & Documentation

Linde Hydraulics GmbH & Co. KG

Wailandtstrasse 13

63741 Aschaffenburg

Germany

Phone +49 (0) 60 21.15 01 48 31

Fax +49 (0) 60 21.15 01 47 35

[info@linde-hydraulics.com](mailto:info@linde-hydraulics.com)

[www.linde-hydraulics.com](http://www.linde-hydraulics.com)

## How to reach us.

Internet    www.linde-hydraulics.com  
Phone        +49 60 21 15 00 0 (switchboard)  
Fax            +49 60 21 15 01 47 35  
E-Mail        info@linde-hydraulics.com  
Mail           Linde Hydraulics GmbH & Co. KG  
                  Wailandtstrasse 13  
                  63741 Aschaffenburg  
                  Germany

## Sales Companies.

- [E]            **Linde Hydraulics Ibérica S.L.**  
Avda. Prat de la Riba, 181, 08780 Pallesa (Barcelona), Telefon +34 93 663 32 58,  
[info@linde-hydraulics.com.es](mailto:info@linde-hydraulics.com.es)  
[www.linde-hidraulica.es](http://www.linde-hidraulica.es)
- [F]            **Linde Hydraulics France SARL**  
1, rue du Maréchal de Lattre de Tassigny, 78854 Elancourt, Telefon +33 1 30 68 46 75,  
[info@linde-hydraulics.com](mailto:info@linde-hydraulics.com)  
[www.linde-hydraulics.fr](http://www.linde-hydraulics.fr)
- [GB]          **Linde Hydraulics Ltd.**  
12-13 Eyston Way, Abingdon Oxfordshire OX14 1TR, Telefon +44 1235 522 828,  
[enquiries@lindehydraulics.co.uk](mailto:enquiries@lindehydraulics.co.uk)  
[www.lindehydraulics.co.uk](http://www.lindehydraulics.co.uk)
- [I]            **Linde Hydraulics Italia S.p.A.**  
Viale dell'Unione Europea, 33, 21013 Gallarate (VA), Telefon +39 0331 1 824 910  
[info.it@linde-hydraulics.com](mailto:info.it@linde-hydraulics.com)  
[www.linde-hydraulics.it](http://www.linde-hydraulics.it)
- [USA]        **Linde Hydraulics Corporation**  
5089 Western Reserve Road, Canfield Ohio 44 406, Telefon +1 330 533 68 01  
[info.us@linde-hydraulics.co](mailto:info.us@linde-hydraulics.co)  
[www.linde-hydraulics.us](http://www.linde-hydraulics.us)
- [BR]          **Linde Hydraulics South America**  
Av, Leônico de Magalhães, 1004 Cj. 03302042-001, Jardim São Paulo, São Paulo, Telefon +55 11  
22 81 78 79  
[Info.br@linde-hydraulics.co](mailto:Info.br@linde-hydraulics.co)  
<https://www.linde-hydraulics.us>
- [PRC]        **Linde Hydraulics (China) Co., Ltd.**  
No. 169 Weian Road, Weifang City, Telefon +86 592 53 87 701,  
[info@linde-hydraulics.com.cn](mailto:info@linde-hydraulics.com.cn)  
[www.linde-hydraulics.com](http://www.linde-hydraulics.com)

Linde Hydraulics GmbH & Co. KG  
Wailandtstrasse 13  
63741 Aschaffenburg  
Germany

[www.linde-hydraulics.com](http://www.linde-hydraulics.com)

Issue 07.2018

